



AKKAYA
B O I L E R S

USER MANUAL

**STK MODEL
UNDERFEED STOKER**



UNDERFEED STOKER SYSTEMS



Figure 1 Underfeed Stoker System on a Hybrid Boiler

In underfeed stoker systems solid fuels are transferred to the combustion chamber by means of an auger. Akkaya Stoker systems have a two-stage transfer system. The fuel is transferred with a short auger to the secondary (longer) auger. By this system it is possible to keep the fuel transportation tube free of fuels to prevent backfire. The fuel is fed to the stoker's fuel pot inside the combustion chamber. The combustion occurs at the top of this fire pot. Stoker number and capacities are selected according to boiler model and capacity.

Stoker bodies are manufactured from special alloy cast iron slices. These replaceable slices are resistant to high temperatures.

The stokers have fire extinguishing and backfire prevention system. There is a mechanical safety thermostatic valve which opens automatically when its sensor reaches to 90° C. It is installed on the fuel transfer tube. There is also an electrical thermostat which operates the secondary auger to empty the fuel transfer tube when high temperature is detected.

Bunker fuel level control automation is available upon request. Fuel mixing arms or airlocks are also optional equipment that can be selected according to the fuel type.

Primary and secondary air fans are provided for homogeneous and optimum combustion. Primary fans are installed on the stoker. Secondary fan is installed on the boiler's front chamber sides.



Figure 2 Underfeed Stoker System on Semi Cylindrical Boiler

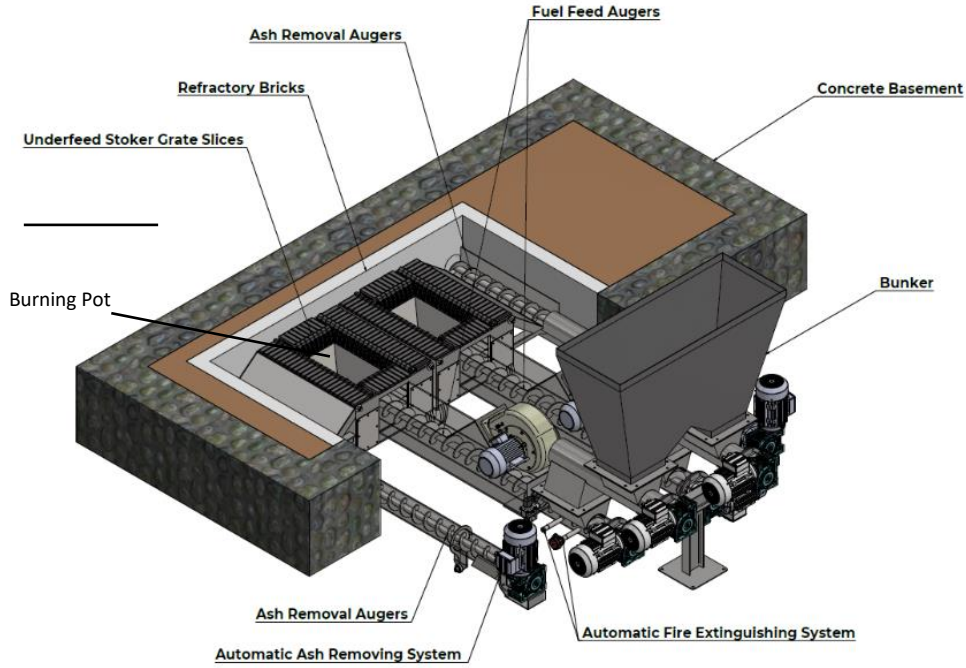

Figure 3 Underfeed Stoker System Components

The proper fuel specifications for underfeed stoker:

Moisture:

The moisture level is suggested to be as low as possible (less than 5%) to obtain required power out of combustion. The moisture level can affect the particle structure of the fuel which is quite important for transportation with screw augers. The high moisture can cause slag formation and unburnt ash formation. Considering all these factors the moisture level must be kept below 30%.

Dimensions:

5-50 mm particle size.

200 – 1100 kg/m³ density

It should have a density and particle structure suitable for transportation with an automatic screw system. The fuel must not cause accumulation or bridge formation in the fuel bunker, it must easily fall from the screw. If bridge formation occurs inside the bunker, additional measures like mixing arm installation must be applied.

Calorific Value:

The preferred calorific values are within the range of; Min. 3000 kcal/kg Lower Calorific Value (LHV) – Max. 7500 kcal/kg (LHV). The boiler's combustion chamber volume design, stoker's surface area selection, fuel feeding rate, heat transfer surface area construction and steam output capacity of the boiler depend on the calorific value of the fuel. The calorific value changes by the moisture level and fuel's elementary structure. The correct selection of the fuel is quite important to get the required heat output.

Ash Content:

The chemical composition of the fuel and the structure of the ash should not allow slag formation. The ash melting temperature should be above 1000 °C. For normal operation, the ash content ratio by mass is recommended to be between 10% and 25%.

The solid fuels composition has big impact on the combustion efficiency and safe operation of the boiler please check the below table to understand the effect of elements on fuel composition.

SUBSTANCE IN FUEL COMPOSITION	Unit	EFFECTS
S SULFUR	kg/kg	S > 0.1wt% (d.b.): There is a risk of corrosion. It is necessary to increase the thickness of the material in the boiler or the need for coating application occurs in critical areas. An automatic cleaning system should be installed, frequent cleaning should be done. It is recommended to change or leach the fuel. S > 0.2wt% (d.b.): There is an additional risk of SO _x emissions. The fuel should be leached, and a special filter should be used for precaution.
N NITROGEN	kg/kg	N > 0.6wt% (d.b.): There is a risk of NO _x emissions. Attention should be paid to EGR, air and combustion chamber design. Additional warning N > 2.5wt% (d.b.): There is a high risk of NO _x emissions, SNCR or SCR should be applied.
Cl CHLORINE	kg/kg	Cl > 0.1wt% (d.b.): There is a risk of corrosion and HCl emissions, it is necessary to increase the thickness of the material in the boiler or the need for coating application occurs in critical areas. An automatic cleaning system should be installed, frequent cleaning should be done. It is recommended to change or rehabilitate the fuel. Use a special filter for HCl emission. Cl > 0.3wt% (d.b.): It is recommended to use PCDD/F emission risk and activated carbon filter as an additional warning.
Ca CALCIUM	kg/kg	Ca > 35wt% (d.b.): There is a risk of low ash melting temperature. It is recommended to apply a water-cooled grate and a low combustion chamber temperature. There is often a need for cleaning the grate and boiler.
K POTASSIUM	kg/kg	K > 7wt% (d.b.): Low ash melting temperature, there is a risk of pollution, slag, corrosion, and aerosol formation. It is recommended to apply a water-cooled grate and a low combustion chamber temperature. Increase material thicknesses or apply coating in critical areas, install automatic cleaning system, need to clean the grate and boiler often. Special filter application and fuel reclamation are recommended
Zn ZINC	kg/kg	Zn > 0.08wt% (d.b.): There is a risk of unburned ash, pollution, high emission of particles. Heavy metal separation, ash recycling system, automatic cleaning system should be installed. The need for frequent cleaning of the grate and boiler occurs. Special filter application and fuel reclamation are recommended.
Cd CADMIUM	kg/kg	Cd > 0.0005wt% (d.b.): There is a risk of unburned ash, pollution, high emission of particles. Heavy metal separation, ash recycling system, automatic cleaning system should be installed. The need for frequent cleaning of the grate and boiler occurs. Special filter application and fuel reclamation are recommended.
TashM Fuel Ash Melting Temperature	C	TashM < 1100 °C: There is a risk of slag and high pollution. Automatic cleaning, water cooled grate, boiler with low furnace temperature and frequent grate and boiler cleaning are recommended.
Fuel with size (0-5 mm)	%	>10%: There is an increase in the amount of fly ash and a decrease in combustion efficiency.

Fuel Feeding and Ash Removal Adjustments of the Underfeed Stokers

The following recommendations should be considered to achieve good combustion in underfeed stokers.

- If the fuel dimensions and characteristics are as recommended (such as pellets), the fuel feeding and waiting time should be adjusted so that the fuel remains around 5 cm from the edges of the pot surface. A smooth curved pattern of fuel pile on top of the pot as seen at below pictures must be reached.

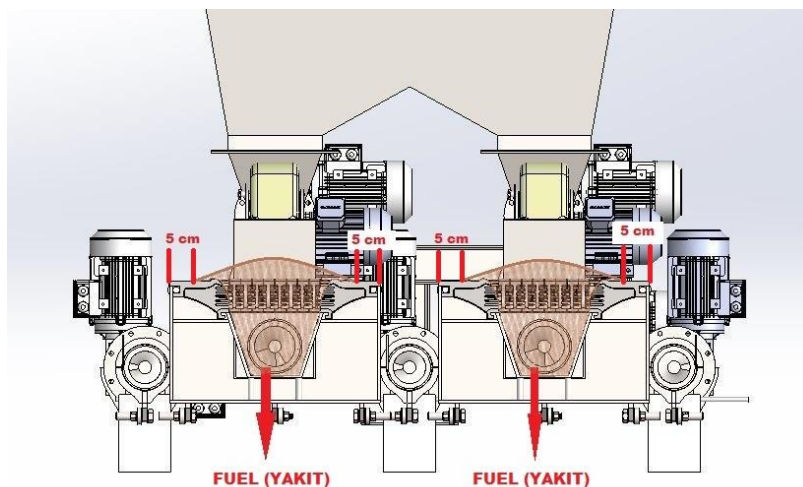

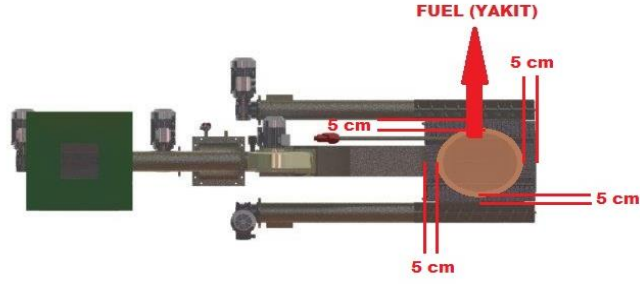

Figure 4 Fuel Distribution on The Stoker Pot

- b) If the fuel has a lighter and more volatile structure than the recommended properties (this type of fuel is not recommended), the fuel should be burned by trapping it in the filling chamber of the stoker pot. Fuel level should be 3-5 cm below the pot surface.

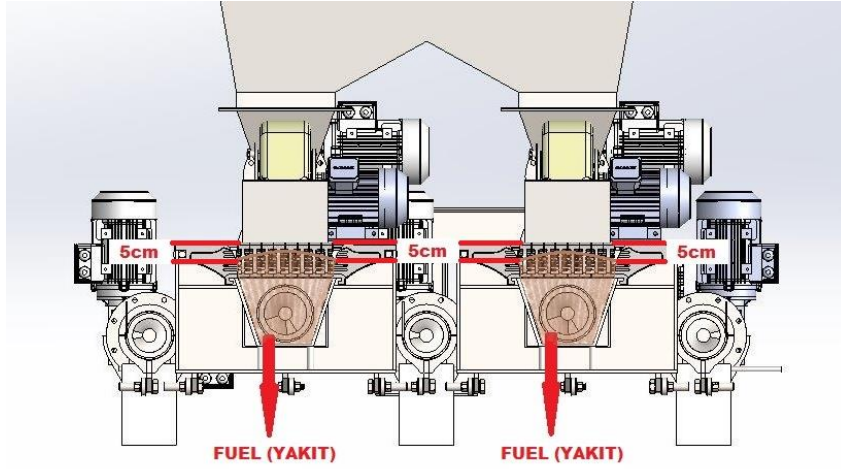

Figure 5 Fuel Distribution of Light Fuels on The Stoker Pot

- c) If there is automatic ash removing system to protect the ash remover screws from unburned fuels and high temperature, the ash in ash extraction systems should always be kept 5 cm above the ash carrying screws (augers). Ash discharge dampers should be checked frequently to ensure that they are fully closed. If any ash and slag are trapped in the covers of these dampers, they must be cleaned manually. If the dampers are not fully closed, air enters the ash removing system and causes burning and deformation in that area. In addition, the air sucked from the ash damper also disrupts the air/fuel adjustment in the boiler combustion chamber. Ash discharge is of great importance. If ash accumulates excessively, there is a possibility of slag forming.

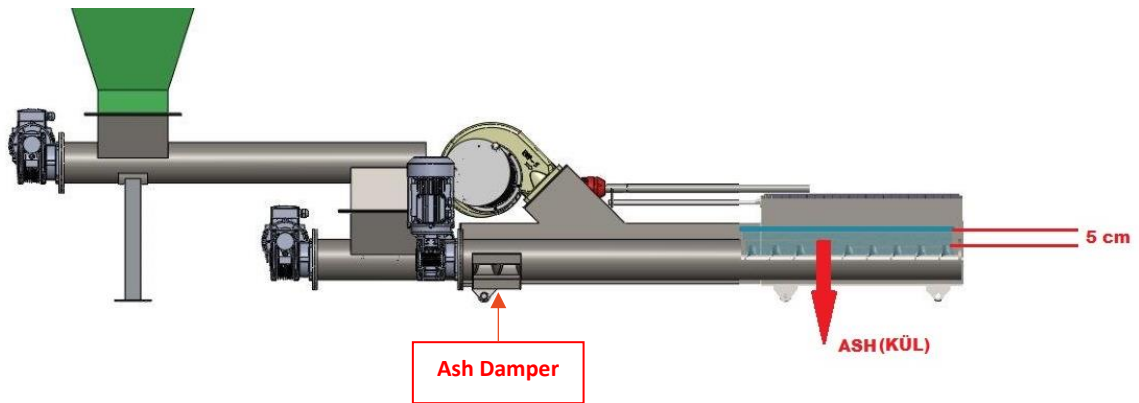

Figure 6 Ash Removing System

- d) To prevent the fire from flowing back towards the bunker, the two-stage feeding must be operated in a manner to ensure that the fuel in the second stage is completely discharged. This is done that way; when the system (boiler) will go to a standstill, the second stage screw must operate 10 more seconds than the first stage screw. (This period may vary depending on the design of the system). Akkaya Technical Service must be consulted for proper adjustment.

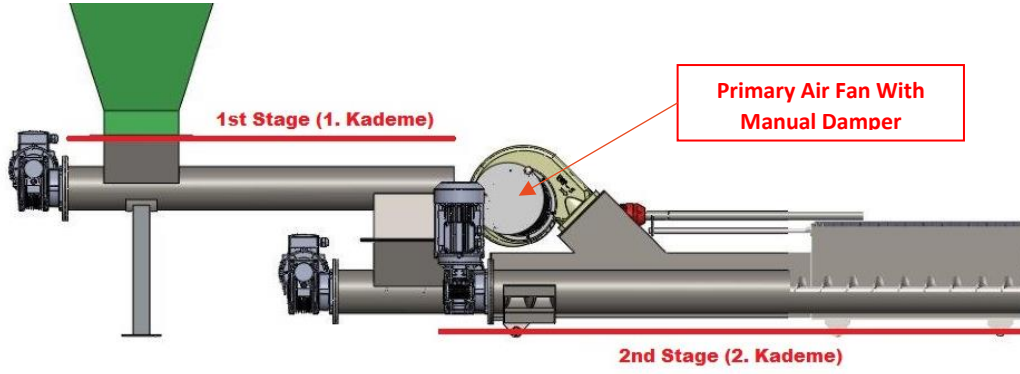

Figure 7 Fuel Feeding System Stages & Primary Air Fan

- e) The adjustment of the air sent to the combustion chamber by the primary and secondary air fans is done by the manual flaps on the fans. While the primary air fan is located on the stoker, the secondary air blower is a unit that is directly connected to the boiler body and is separate from the stoker. The outlet of the primary air fans has an automatic damper for safety. This air damper is controlled by means of a pneumatic actuator. This damper opens when the primary air fan is activated and closes when the fan is disengaged. When it is in the closed position, air entry into the combustion chamber is blocked. By this way, unwanted combustion is prevented.

Stoker Installation & Basement Preparation

Installation preparation for the underfeed stoker must be done by consulting with Akkaya Design Team. A sample photo of a basement preparation can be found below.



As the solid fuel burning and fuel feeding systems are designed specifically according to the customer's requests, additional information from Akkaya technical team must be asked for each system design.



 1. OSB Yerli Su Sokak No: 2
Selçuklu /Konya / Turkey

 **+90 332 248 92 21**
+90 332 248 91 45

 **+90 332 248 77 10**

 **akkaya@akkaya.com.tr**

 **akkaya.com.tr**

   **/akkayaboilers**