



AKKAYA
B O I L E R S

USER MANUAL

**KBB MODEL
STEAM BOILERS**





INDEX

1. Introduction	4
2.General Design and Constructlon Features.....	6
2.1 Design	6
2.2 Working Principle	7
2.3 Construction.....	7
2.4 Quality.....	8
2.4.1. Steel Materials.....	8
2.4.2 Tubes	8
2.4.3 Welding	8
2.4.4 Isolation.....	8
2.5. Product Coding	9
2.6. Boiler Name Plate (sample).....	9
3. Transportation Instructions	11
3.1. Placing the Boiler on Transport Vehicle	11
3.2. Transporting The Boiler	11
3.3. Placing The Boiler In The Boiler Room.....	11
4. Installatlon of Boller and Auxlllarles	13
5. Start-Up , Operating, Cleaning and Maintenance	16
5.1 Start-Up And Operating The Boiler.....	16
5.2 Shutdown And Discharging The Boiler	19
5.3 Shutdown Procedures At Emergency Situations.....	19
5.4 Precautions	19
5.5 Cleaning & Maintenance.....	20
5.6 Protecting The Non-Operating Boiler.....	21
5.7 Feed Water And Boiler Water Quality	22
APPENDIX 1 -Sample Daily Control Chart.....	25
APPENDIX 2 -WATER QUALITY REQUIREMENTS	26
APPENDIX 3 - Dimension Table of KBB - e Model Boilers	28
APPENDIX 4 - system Accessories and Auxiliary Equipment Explanations	29
APPENDIX 4.1 Burner	29
APPENDIX 4.2 Steam Exit Valve.....	29
APPENDIX 4.3 Bottom Blowdown & Drain Valve Group.....	30
APPENDIX 4.4 Surface Blowdown Valve and System.....	31
APPENDIX 4.5 Sample Cooler	32
APPENDIX 4.6 Boiler Water Inlet Valve & Check Valve	32



APPENDIX 4.7 Safety Valves	33
APPENDIX 4.8 Automatic Boiler Water Level Controllers.....	33
APPENDIX 4.9 Reflex Glass Boiler Water Level Indicator	35
APPENDIX 4.10 Pressure Switches.....	35
APPENDIX 4.11 Pressure Transmitter	36
APPENDIX 4.12 Manometer & Manometer Valves	36
APPENDIX 4.13 Boiler temperature control and alarm system (Thermocouple).....	37
APPENDIX 4.14 Exhaust Gas Temperature Sensor	37
APPENDIX 4.15 Vacuum Breaker.....	38
APPENDIX 4.16 Electrical Control Board	38
APPENDIX 4.17 Water Softener	39
APPENDIX 4.18 Condensate Tank Without Heater	39
APPENDIX 4.19 Pre-Heated Condensate Tank (Atmospheric Deaerator)	40
APPENDIX 4.20 Condensate Tank with Spray Scrubber Type Compact Deaerator.....	41
APPENDIX 4.21 Feed Water Pump Group	43
APPENDIX 5 -BOILER CONTROL SYSTEM STANDARD Alarms Explanations.....	44
Boiler Water Low Level	44
Boiler Water High Level	44
Low Temperature Alarm	44
High Temperature Alarm.....	44
High Pressure Alarm	44
-Burner Error/ Failure	44
Feed Water Pump & Solenoid Operation.....	44
Hooter/ Siren Shutdown	44
Manual Restart Button	44
Burner Alarm Reset.....	44

1. INTRODUCTION

Valuable Customer,

Akkaya steam boiler you have purchased is produced according to EN & TURKISH norms.

This user guide is prepared for Akkaya KBB model, oil or gas fired steam boiler.

This user guide includes technical information about the boiler and operating and safety instructions as well.



Owner must employ a licensed or certificated boiler operator for a safe and efficient use. Any accidents or breakdowns caused by operating conditions, other than described in this guide, shall be customer's responsibility. All local legal requirements must be fulfilled by the owner prior and during operation of the boiler.

TS 2025-2021 standard must be followed for a safe operation. (This standard covers general rules for operation inspection and maintenance of steam boilers.)

There are some information and charts referred to standards and norms in this manual. Please refer to the latest versions of the standards and norms.



GENERAL DESIGN and CONSTRUCTION



2.GENERAL DESIGN AND CONSTRUCTION FEATURES

2.1 Design

- KBB model boilers are designed and manufactured according to the system which transfers the usable heat of combustion gases to the water by the reverse flame & 2 passes principle of gases inside the boiler.
- KBB boilers are “wet back” boilers, which means the back side of the combustion chamber (fire tube) of the boiler is water cooled. This allows longer lifetime for the boiler and decreases the problems caused by refractory breakdowns in dry back boiler systems.
- The heat transfer area of the boiler and the combustion chamber dimensions are selected properly to gain more heat by radiation. There are turbulators placed in the smoke tubes. These turbulators increases the heat transfer amount of the boiler significantly.
- For the high operating pressure values, the furnace is produced in corrugated form to eliminate thermal expansions and to obtain sufficient strength.
- Isolation of the boiler is specially made to minimize the thermal energy loss. Special covering materials are used on the surface, to protect the shell of the boiler from outdoor conditions and to prevent the tearing at maximum.
- Front door hinges are designed for effortless operation. Opening the front door is quite easy and safe.
- Rear smoke box and front door side panels are isolated by ceramic-based insulation materials to decrease heat loss and to let safer operation. At the front door high temperature resistant refractory cement is used.
- The boiler body is designed according to PED2014/68 directive and CE marked.
- EN12953, EN13445 & EN1090 norms are followed where applicable.
- Akkaya Boilers has ISO3834 & ISO9001 quality system certificates.

2.2 Working Principle

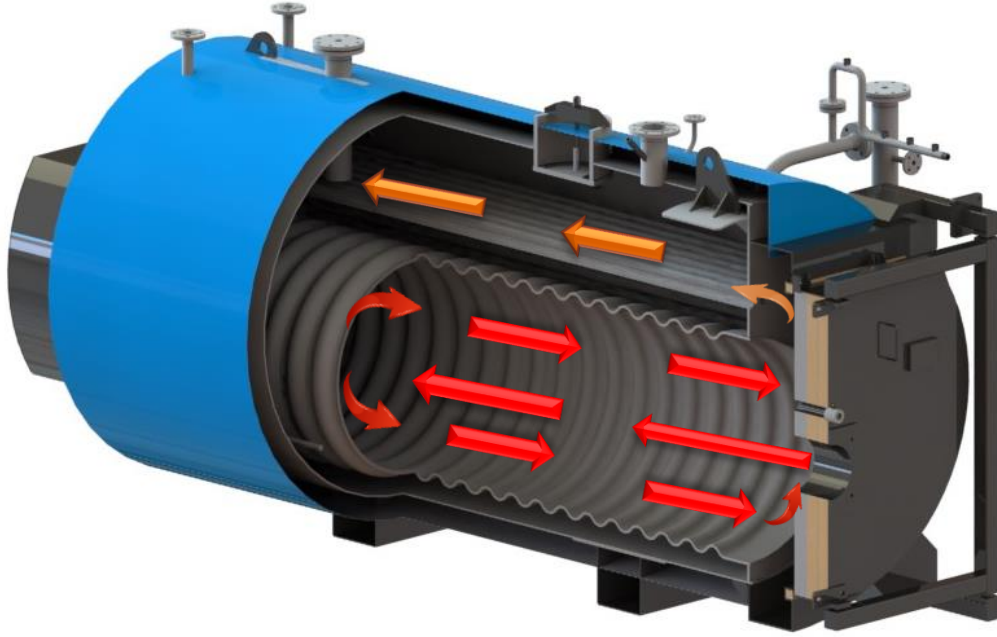



Figure 2.2.1 KBB Boiler Working Principle

-  : FIRST STAGE WITH FLAME REVERSE
 : SECOND STAGE

The flame from the burner first reaches to the back wall of the furnace (wet back) and here it turns back to the front door. At the front door hot gases pass to the smoke tubes. Then the hot gases reach at the rear smoke box to be discharged from the chimney to the atmosphere.

2.3 Construction

KBB boiler body consists of a: Cylindrical, 2-pass, fire tube, wet back main body, mirror plates and plain or corrugated furnace at proper thickness, according to the boiler's operating pressure. EN12953 is taken as reference for design calculations where applicable.

2.4 Quality

2.4.1. Steel Materials

Steel materials are selected according to the requirements of EN12953-2. Generally, boilers are made of carbon steel of quality P265GH - P295GH -P355GH in accordance with EN10028-2 standard in the pressure-exposed parts and of S235JR - S355JR quality in non-pressure parts. The details of the materials used can be found in the “Technical File” of the boiler.

2.4.2 Tubes

In accordance with the requirements of EN12953-2: EN10216-2 P235GH, 16Mo3 or similar quality seamless steel tubes and EN10217-2 P235GH quality ERW (welded) tubes are used. The details of the materials used can be found in the “Technical File” of the boiler. Stainless steel turbulators are placed inside the tubes to increase the heat transfer.

2.4.3 Welding

Welds were performed by certified welders according to EN9606, in accordance with EN15609, EN15614-1, EN15614-8 requirements of welding procedure specifications. According to EN12953-5, welds are subjected to necessary non-destructive testing procedures (UT / RT, VT, MT / PT). The weld details including WPS, PQR, welding maps, NDT reports, welder certificates can be found in the “Technical File” of the boiler.

2.4.4 Isolation

On 100 mm thick and 80 kg / m³ dense rockwool, PVC and protective film coated galvanized sheet, aluminum or, stainless steel coating (specifications of which can be changed according to customer request) is applied. Rear smoke box and front door side panels are isolated by refractory and ceramic-based insulation materials to decrease heat loss and to let safer operation.

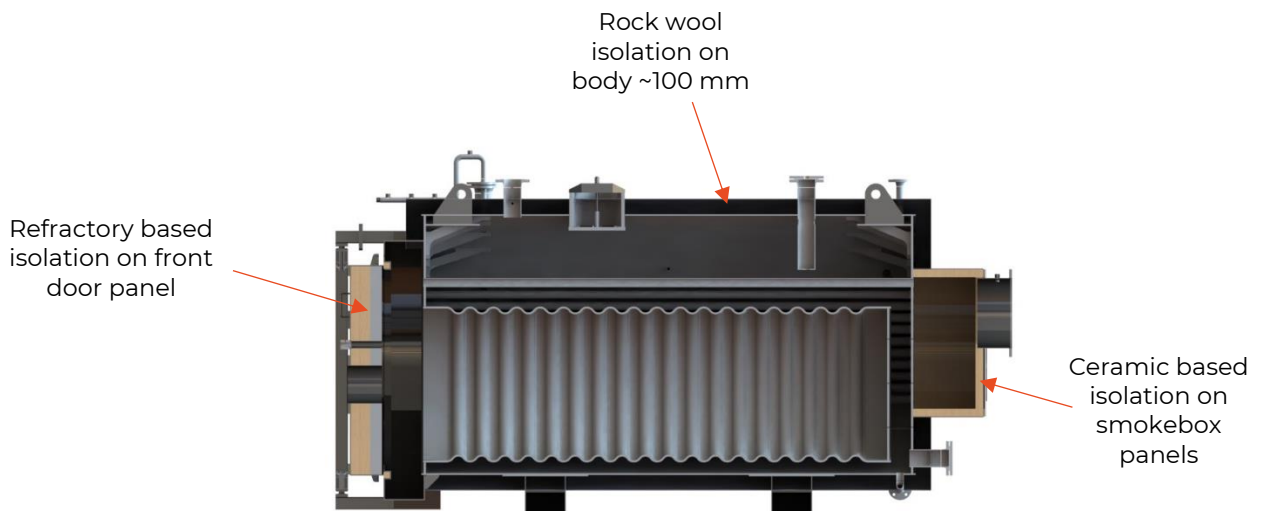
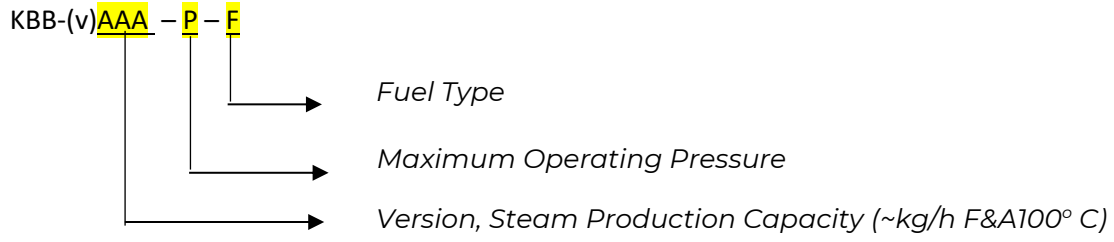



Figure 2.4.4.1 Isolation

2.5. Product Coding



2.6. Boiler Name Plate (sample)

**AKKAYA**
B O I L E R S
AKKAYA ISI MAKİNALARI VE DOĞALGAZ SAN. VE TİC. A.Ş.
AKKAYA HEATING INSTRUMENTS & NATURAL GAS INC.

Tanım Description	_____
Tipi Type	_____
Seri No Serial Number	_____
Standart Standard	_____
Max. Isıl Kapasitesi Maximum Thermal Capacity	_____
Akışkan Tipi Fluid Type	_____
Isıtma Yüzeyi Heating Surface	_____
Müsaade Edilen En Yüksek Basınç Max. Allowable Working Pressure	_____
Müsaade Edilen En Yüksek Sıcaklık Max. Allowable Working Temperature	_____
Hidrostatik Test Basıncı (bar) Hydrostatic Test Pressure (bar)	_____
Hidrostatik Test Tarihi Hydrostatic Testing Date	_____
İmalat Tarihi Manufacturing Date	_____

CE

1.OSB.Yerli Su Sok. No:2
Selçuklu / KONYA - TURKEY
+90 332 248 92 21
+90 332 248 91 45
akkaya@akkaya.com.tr

www.akkaya.com.tr



TRANSPORTATION INSTRUCTIONS



3. TRANSPORTATION INSTRUCTIONS

3.1. Placing the Boiler on Transport Vehicle

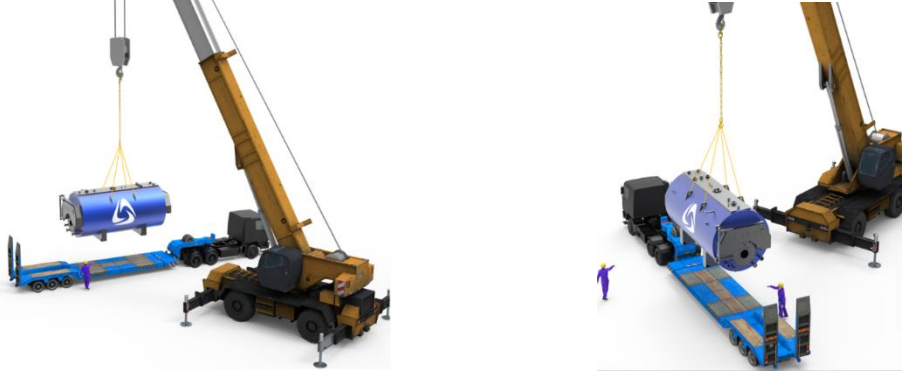

Figure 3.1.1 Placing Boiler on Transport Vehicle

- 1- An open top vehicle must be selected for transportation of the boiler (either with truck or container)
- 2- While loading boiler on a vehicle, a crane (with proper load capacity) must certainly be used. All the covers / doors of the vehicle must be opened before the boiler is lifted for placing.
- 3- Lifting eyebolts of the boiler must be used while lifting to place it on the vehicle. (In Figure 3.1.1)
- 4- Rope or chain must be selected carefully to carry the boiler safely. Connection and angle of the ropes/chains must be done according to the instructions & confirmations given by Akkaya.
- 5- Placing on the vehicle and positioning the boiler must be done carefully and instructions from the transport vehicle operator must be followed.
- 6- The lashing of the boiler on the vehicle or container must be carried out by professional and certificated companies.



When you lift the boiler from the ground level, there must be **NOBODY under or close to the boiler. Utmost care must be taken to avoid accidents.**

3.2. Transporting The Boiler

- 1- Before carrying the boiler on a vehicle, it must be fixed to the vehicle by being tied with barrier to prevent slipping. The lashing must be done by certificated companies.
- 2- Boiler mustn't be carried together with fragile equipment and/or living creatures.
- 3- The driver of the vehicle must avoid any sudden movements. The speed limits of the road must strictly be obeyed.

3.3. Placing The Boiler In The Boiler Room

- 1- Boiler must be placed in a boiler room, specially built for boiler and boiler auxiliaries.
- 2- Local legal regulations and rules or TS2025-2021 (whichever is stricter) must be followed for the boiler room placement and construction.
- 3- Boiler must be unloaded from the vehicle, using a crane. The eyebolts of the boiler must be used for crane operation.
- 4- If it is not possible to take the boiler inside the boiler room, either from its roof or doors, some agents like rollers or similar items can be used to slide the boiler on.
- 5- Experienced staff must be in charge for unloading and placing the boiler in the boiler room. Safety tools like helmets, gloves, eye protectors... etc. must be provided.
- 6- The boiler room must be free from dust, flammable materials, dangerous or corrosive gases.
- 7- The fire protection & extinguishing system must be installed.



INSTALLATION OF BOILER AND AUXILIARIES



4. INSTALLATION OF BOILER AND AUXILIARIES

For the boiler room dimensions and construction rules please refer to the local regulations or TS 2025 standard. Please consult Akkaya for the dimensions of the boiler and auxiliary equipment to be installed inside the boiler room.

- 1- All required legal permissions for boiler fuel supply, electrical power supply, piping & plumbing must be completed and provided by the owner.
- 2- The height of the boiler room must be built at least 2 m higher than boiler's height.
- 3- The boiler room must have at least two facing doors one of which must have ventilation openings to allow air circulation.
- 4- The doors must have at least 2 m height and 0,9 m width.
- 5- The boiler room floor must be a smooth concrete or a non-flammable basement.
- 6- The boiler room must be well ventilated but protected from outdoor conditions or wind.
- 7- Any flammable objects mustn't exist in the room.
- 8- The installation of the boiler and its auxiliary accessories must be carried out by an experienced and qualified staff.
- 9- If there is more than one boiler to be installed in the same boiler room, there must be minimum 1 m space between boilers.
- 10- Adequate space must be left to access the boiler for inspection or service purposes.
- 11- Easy access to the electrical control board and sufficient clearance must be provided.
- 12- Pressure drop in the boiler room can be maximum 0,5 mbar. It must be ensured that there is no negative pressure in the boiler room.
- 13- In case any kind of suction fan exists in the boiler room, it must be ensured that boiler flame draft is not affected. In case needed a draft inducer or engineered flue system must be provided.
- 14- The proper steam, condensate and fuel line piping must be completed before the boiler start-up. P&ID (piping and instrumentation diagram) and item list of the equipment must be provided and must be kept for future records.

If the auxiliaries and accessories of the steam boiler is in the scope of contract P&ID and item list is supplied by Akkaya. Please consult Akkaya for these documents.



The owner of the boiler must complete the following pre-works before start-up.

- 1- Proper water supply line and water drain must be built.
- 2- Water softening system must be connected to raw water inlet and to condensate tank inlet. For the specifications of the water to be connected to the feed water tank and to the boiler feed pump is described in the user manual and in EN 12953-10 standard.
- 3- Piping between condensate tank or deaerator to feed water pumps and from pumps to boiler must be done. For the dimensions of the pipes please refer to P&ID.
- 4- A proper electrical power supply cabling to the electrical control board must be done and its earthing (grounding) must be completed. Please refer to the electrical wiring diagram for selection of the power supply cables and protection switches (to be supplied by Akkaya if the control system supply is in the scope of the contract).
- 5- In case the boiler is not delivered as a packaged system with all accessories mounted on, Akkaya's authorized staff must be waited to connect all the accessories to the boiler. Also, the electrical control board connection of the boiler accessories shall be done by Akkaya's technicians, too if these works are in the Akkaya's scope of supply.
- 6- The safety valve outlets must be taken out of boiler room with proper separate piping for each of them. Do not connect the exits of the safety valves to a common pipe.
- 7- Boiler must be connected to a properly designed and certificated chimney. The calculations and the construction of the chimney and the smoke channels must be done according to EN norms.



Too long horizontal section or improper sized smoke channels may cause poor draft. Chimney draft is very important for the combustion quality. Also, the diameter of the chimney is very important for draft and must be selected properly.

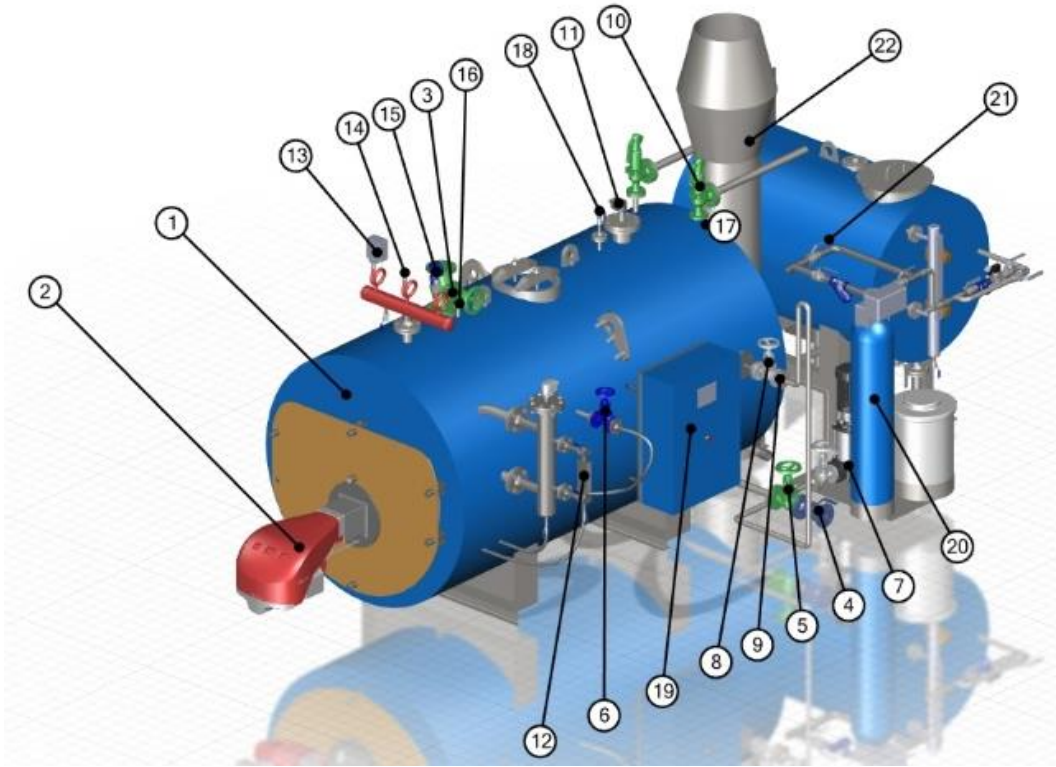

No	Component	No	Component
1	Boiler Body	12	Reflex Glass Boiler Water Level Indicator
2	Burner	13	Pressure Switch
3	Steam Exit Valve	14	Pressure Transmitter
4	Bottom Blowdown Drain Valve	15	Manometer and Manometer Valve
5	Bottom Blowdown Shut Off Valve	16	Boiler Temperature Sensor
6	Surface Blowdown Valve	17	Exhaust Gas Temperature Sensor
7	Boiler Feed Water Pump Group	18	Vacuum Breaker and Shut Off Valve
8	Boiler Water Inlet Valve	19	Electrical Control Board
9	Boiler Water Inlet Check Valve	20	Water Softner
10	Safety Valve	21	Feed Water Storage (Condensate) Tank
11	Boiler Automatic Water Control System	22	Chimney

Figure 4 Sample Boiler Accessories & Auxiliaries

The configuration and the equipment descriptions given in this manual are for a standard package KBB boiler system. The specifications and quantities of the accessories may vary due to customer's requests. For safety accessories EN12953 has been taken as reference where applicable.



START-UP, OPERATING, CLEANING AND MAINTANENCE INSTRUCTIONS



5. START-UP , OPERATING, CLEANING AND MAINTANENCE

5.1 Start-Up And Operating The Boiler



The boiler's first start-up & commissioning must be done by Akkaya's Technical Service. The guarantee of the boiler will be invalid unless the commissioning is done or approved by Akkaya.

When the boiler is turned off manually and needs to be started up again the following steps must be completed to operate the boiler safely.

Boiler operators must have a valid license, or a certificate taken from official authorities (In Türkiye MYK certification is required). The operators must be responsible for interfering in any urgent situation. So, it is very important that they know the functional properties and operating principles of all equipment used in boiler systems.

The operators must have a control form and must fill it in daily.

[For sample daily control chart see Appendix 1]

- 1- All combustion equipment and chimney system must be checked for a safe operation. This check is done to be sure:
 - a) There is no unfired fuel / oil / flammable object deposit inside the combustion chamber.
 - b) There is no gas deposition inside the boiler.
 - c) There is no leakage at the fuel line and the boiler & burner peripheral is clean and free from fuel / oil / flammable object.
 - d) The chimney and smoke channels are open and clean. Proper suction exists in the combustion chamber. There are no hurdles in the smoke way. All the auxiliaries' (like economizer, recuperator, etc.) dampers are fully open, and smoke can pass through easily.
 - e) There are no hurdles in front of the gas explosion door, and it is functioning well.
- 2- If there is any automatic combustion or control equipment in the system; electrical protection and functional controls and locking system controls must be done. All this equipment must be in operation.
- 3- All blowdowns, discharging valves, feed water manual valves must be checked for no leakage.
- 4- Automatic water level control system of the boiler must be checked strictly, for correct operation. The correct operation of this system must be ensured before the boiler is started-up. These controllers can be checked during manual filling of the boiler.
- 5- If the steam boiler has stayed non-operating for more than 2 weeks, all valves, fittings and control equipment must be checked for any kind of faults before restarting.
- 6- Feed water with appropriate chemical composition complying with EN12953-10 must be filled in the boiler from feed water tank. Akkaya control systems has a manual filling option on the control board.
- 7- Water level indicators must be controlled by making blowdowns from their bottom drain valves. The water level in the glass must be observed and the water level must be in normal level.

[For feed water chemical composition information see Appendix 2]



Akkaya's manufacturer guarantee shall not be valid unless above mentioned chemical composition of feed water is provided.



Before the first ignition of the burner make sure that there is nobody in front of the boiler doors or in front of the explosion door. At this stage boiler operator(s) must stay at the side of the boiler. There may be a gas explosion and the boiler doors, or the burner can blow away by this explosion. This may cause deadly injuries.

- 8- The boiler combustion system can be ignited, or the boiler can be started after making all the checks described above. **Before the first ignition of the burner make sure that there is nobody in front of the boiler doors or in front of the explosion door. At this stage boiler operator(s) must stay at the side of the boiler. There may be a gas explosion and the boiler doors, or the burner can blow away by this explosion. This may cause deadly injuries.**

- 9- Steam discharge valve must be controlled manually by opening and closing it. This valve must not be tightened too much during steam supply regarding expansion or squeezing.
- 10- The control values like pressure, steam temperature and stack temperature must be observed. Steam pressure manometer and the pressure value on the control screen obtained by the pressure transmitter must be observed and controlled. There may be slight difference between mechanical manometer and digital value on the screen. If the difference is higher than 0,2 bar Akkaya Technical service must be informed. The temperature of the steam can be controlled after letting some amount of steam flow from the boiler. The stationary steam or water temperature can be different than the actual value. The temperature of the steam must be close to the saturation temperature of the steam at that pressure. If the temperature value is not compatible with the saturation temperature Akkaya Technical Service must be informed.
- 11- Combustion Air to Fuel ratio adjustment must be done by an expert with an exhaust gas analyzer.
- 12- During first ignition the burner must be operating less than its full capacity. The flame must be observed at minimum length at least one hour without increasing.
- 13- Water level rises because of temperature increase due to thermal expansion. Water level inside the boiler can be decreased to the normal level by making bottom blow down manually.
- 14- After obtaining homogenous heat inside the boiler, the burner flame and the boiler pressure can be increased gradually. (For example, 1 bar every 15 minutes). Sudden pressure increase must be avoided.
- 15- When the boiler pressure reaches the set value the burner must stop automatically. There may be a hysteresis set value for restart of the burner. This value must be checked and if it is not well defined for the steam consuming process Akkaya Technical Service must be informed. The burner may be two stage or modulating type; in this case the set value of the 1st and 2nd stages and the modulating operation of the burner must be checked, if the operation of the burner is not stable the burner's technical service must be informed.
- 16- Safety valves operation must be checked. When the boiler pressure reaches set value, the safety valves handles can be lifted to let some steam flow. Never try to increase the pressure of the boiler to the safety valves set value by firing the burner (by making shortcut in burner control line). The check of the safety valves at their set values can only be done by authorized Akkaya Technical Services.
- 17- Check all the flange or nozzle connections for water or steam leakages during the pressure rise of the boiler.



In case any water or steam leakage is detected at a boiler under pressure and when the temperature is higher than 50°C do not attempt to solve the problem immediately. Wait for the boiler and the water to cool down. Be sure that there is no steam inside the boiler. Breathing steam can burn your trachea and cause suffocation. Steam can burn your skin. Pressurized steam can cause mechanical elements (like bolts, nuts, valves, handles, etc.) to rupture and hit your body. These incidents can cause fatal injuries. Utmost care must be taken during eliminating any leakage.

- 18- After the boiler reaches set pressure value, bottom blow down must be done by opening the bottom blow down valve at the back side of the boiler. If the valve is manual, make the blowdown for 3 seconds in every 8 hours. If there is an automatic blowdown valve, check its working and waiting time set values. For the first start-up of the boiler, check the controllers' operation manually to see if the automatic valve is open or shut off properly.
- 19- Surface blow down must be done from the surface blow down valve. If the surface blowdown system is manual, the operator must check the water quality / conductivity / foam formation. After observing the water quality of the boiler and compare it with the values listed in EN12953-10 the period and the **amount** of the blowdown must be determined. If the system is automatic, then the valve will automatically open and shut down according to the measured conductivity value.
- 20- During the boiler's operation, the flame must always be kept stable and smooth regardless the fuel type. The boiler operator must also check the fuel consumption and follow it to notice any kind of efficiency loss.
- 21- Water level must stay at normal level when boiler is operating. Even if the water level is controlled automatically, boiler operator must still observe the level as the automatic system may be out of order because of mechanical or electronic breakdowns.
- 22- Water level controllers and water level indicators must be cleaned monthly to obtain safe and efficient operation.
- 23- To let the steam flow through the pipeline, the main steam exit valve must be opened slowly. The steam exit valve of the boiler must be opened slowly with highest attention. Small amount of steam must be discharged until the pipeline's temperature and pressure reaches to the expected values. Sudden steam discharge to the pipeline can cause mechanical problems like steam or water hammering, rupture, or breakdowns due to thermal expansion ... etc.
- 24- Be sure to discharge all condensate in the pipeline before opening the boiler steam exit valve.

- 25- If any foam formation is detected, the boiler must be fed with water (as described in EN12953-10) and surface blow down must be done until the foam formation stops.



If foam formation cannot be eliminated, the boiler must be shot down, and possible reasons must be investigated. Please contact the authorized service for assistance.

- 26- Boiler feed water must be continuously analyzed chemically to prevent improper composition. Water sample must be taken in certain periods and be analyzed as described in Appendix 1 & Appendix 2 of this manual.
- 27- The temperature of feed water and the discharge pressure of the pumps must be kept stable at required normal level. NPSH (net pump suction head) is dependent on the temperature and pressure of water. The height difference between feed water tank and pump effect the pump's suction. Water below 80°C and around 2 mt of water head is advised for standard operations. Please consult Akkaya Technical Service for higher temperature and pressurized feeding systems.
- 28- The feed water pipes and pumps must be controlled frequently (Ave. monthly). The calcination or scale formation inside the feed pipeline and especially at the boiler feed water inlet nozzle is a frequently faced issue. In case scaling or mud formation is seen they must be fully cleaned by mechanical or chemical means.
- 29- Blow down of level indicators and mechanical level controllers must be done at least daily. (see Appendix 1)
- 30- Boiler operator must record all the operations done on the boiler regularly.



IF WATER LEVEL DECREASES BELOW THE LOW-LOW LEVEL ALARM LEVEL AND THE BURNER KEEPS ON RUNNING THIS WILL CAUSE OVER HEATING OF THE BOILER PARTS. IN SUCH CASE BOILER&BURNER MUST BE STOPPED IMMEDIATELY. ALL ELECTRICAL POWER SWITCHES MUST BE TURNED OFF. ESPECIALLY FEED WATER PUMPS POWER CONNECTION MUST BE CUT IMMEDIATELY. NOBODY MUST BE ABLE TO RESTART THE PUMPS ACCIDENTALLY. FEED PUMP VALVES, BOILER FEED WATER INLET VALVE, STEAM DISCHARGING VALVE AND BURNER'S FUEL VALVES MUST BE CLOSED. BOILER MUST BE COOLED DOWN BY OPENING ITS FRONT SMOKE DOORS AND BY LETTING COLD AIR ENTER IN THE SMOKE TUBES. NEVER TRY TO FEED WATER TO THE HOT BOILER. NEVER TRY TO COOL DOWN THE BOILER BY FEEDING WATER. AFTER THE REASON FOR LOW LEVEL IS INVESTIGATED AND ELIMINATED IT MUST BE CHECKED FOR ANY MECHANICAL DAMAGE. ESPECIALLY COMBUSTION CHAMBER OR REVERSAL CHAMBER CAN GET HARMED BECAUSE OF LACK OF WATER. IN ORDER TO CHECK THE SITUATION, AKKAYA TECHNICAL SERVICE MUST BE CONSULTED. BOILER MAY EXPLODE IF YOU FEED THE HOT BOILER WITH WATER!



THE FLAME MUST BE OBSERVED DURING BOILER OPERATION. IF THE BURNER DOES NOT STOP AUTOMATICALLY AT THE SET PRESSURE VALUE, THE FUEL VALVE MUST BE CLOSED IMMEDIATELY AND AKKAYA TECHNICAL SERVICE MUST BE INFORMED.



IF THE FLAME CAN NOT BE FORMED IN A SHORT TIME AT THE FIRST IGNITION, THE FUEL VALVE MUST BE CLOSED. THE IGNITION MUST BE TRIED AGAIN AFTER BURNER & COMBUSTION CHAMBER IS FULLY VENTILATED AND CLEANED FROM FUEL RESIDUES. DEPOSITED FUEL RESIDUES OR COMBUSTIBLE GASES MAY CAUSE EXPLOSION!



IF THE BOILER OR ANY OTHER PERIPHERAL EQUIPMENT IS FROZEN DO NOT START THE BOILER BEFORE HAVING AKKAYA'S AUTHORIZED TECHNICAL SERVICE MAKE THE NECESSARY CONTROLS. NEVER TRY TO MELT THE FROZEN PARTS INSIDE THE BOILER BY FIRING THE BURNER. THE BOILER MAY EXPLODE IF YOU TRY TO RUN FROZEN BOILER!

5.2 Shutdown And Discharging The Boiler

- 1- Boiler is electrically shutdown from the control board by pressing stop button on HMI. (For different type of control board system please refer to electrical wiring diagram)
- 2- After shutdown be sure that the burner is fully stopped.
- 3- After the burner is fully stopped, fuel line shut off valve must be closed tightly.
- 4- If the water level is normal, the feed water pump can be turned off (if there is separate pump on/off button on the control board) and feed water inlet valve must be closed.
- 5- If the water level is higher than the normal level, the excess water can be discharged by making bottom blowdown.
- 6- Let the boiler cool down naturally. To prevent sudden temperature changes in the boiler, avoid sudden cooling.
- 7- The reduction of pressure must be observed while the boiler is cooling.
- 8- The boiler can be discharged from bottom blowdown valve after the water temperature is measured below 80 °C and 0 BarG pressure is observed at the boiler manometers.



It is dangerous to discharge the boiler when it is still hot.

- 9- Blow down valves must be closed tightly after the boiler is fully discharged and warning signs as "do not open" on the blow down valves must be placed.

5.3 Shutdown Procedures At Emergency Situations

- 1- If there is an emergency case like low low water level, high temperature, high pressure, or low temperature, press the emergency stop button.
- 2- Be sure the burner and pumps are not working. Close the fuel inlet valve of burner and water inlet valve of the boiler.
- 3- If the system is solid fuel fired boiler. Take out the fire and unburned fuel from the combustion chamber.
- 4- For boilers which have been left without water and heated with lack of water, open the fire tube cleaning doors to let the boiler cool down naturally.
- 5- Never restart the boiler without inspection of an authorized body after an emergency stop.

5.4 Precautions

- 1- Do not fire the boiler if the water is below the normal water level.
- 2- Do not put your hands, your head or any of your body parts into the boiler gas side or water side during operation. Do not enter inside the boiler while the boiler is hot.
- 3- Do not close any of dampers on the smoke way fully. These dampers are boiler stack exit damper, economizer damper, recuperator damper or any damper that can stop the exhaust flow.
- 4- Insufficient chimney draft is harmful for human health and reduces boiler efficiency. So, the boiler draft must be kept adequate by means of cleaning and if needed by installation of a suction fan.
- 5- Chimney must be kept clean and in good condition for sufficient combustion. Before starting the boiler, the chimney draft must be controlled.
- 6- Be careful about the possible leakage at chimney and chimney connections.
- 7- Cleaning door on the chimney connection must be closed during operation.
- 8- The doors of fume box and chimney cleaning door must not be opened during operation.
- 9- Do not open the doors of the boiler during operation.
- 10- Before starting the burner, be sure that there are no flammable objects in the boiler and the furnace is clean.
- 11- You must keep the boiler under control during operation frequently.
- 12- Do not cook anything in the boiler.
- 13- Explosion door behind the boiler must be kept clear to be opened easily. Do not put anything in front of the door.
- 14- Do not use fuel with high sulfur content or materials that are harmful for human health.
- 15- Do not put explosive materials in the boiler.
- 16- There mustn't be any materials that can burn around the boiler (like woods, coal, oil, gas, textile materials, plastic materials ... etc.). Sparks or some heat can get out of the boiler, and this can cause fire. That's why the boiler room and the surrounding of the boiler must always be kept clean and free of materials that can burn.

5.5 Cleaning & Maintenance

The perfect reference for a boiler operator is a clean and well cared boiler room. Obtaining high efficiency and continuous operation depend on boiler's and boiler room's condition.

The cleaning and maintenance cost can be kept at a very low level by performing it correctly and frequently. If done so the boiler will have a very long operating life, high efficiency and return of the investment cost will take shorter time.

General cleaning Instructions:

- 1- All equipment that does not belong to the boiler room must be removed.
- 2- The clean water supply connection and drain connections must exist in the boiler room. The boiler shall be cleaned easily by water.
- 3- The boiler outer shell must be cleaned frequently to keep new and good appearance.
- 4- The control and safety equipment, bushings, flanges must be checked for leakage. If there is no water or steam leakage on any part of the boiler system, the boiler will be clean all the time as there will be no salt, dirt formation or calcification at any part.
- 5- The manholes and flanges must be tightened at least every two months to prevent leakages.
- 6- Front door, burner connection flanges and rear explosion door can be used to clean the gas parts of the boiler.
- 7- If soot layer is less than 0,5 mm, you may leave it. Thicker soot / dirt must be cleaned with special boiler tube brush. The soot inside the tubes decreases the boiler efficiency too much. The turbulators must be taken out of the boiler one by one and must be cleaned or renewed if necessary.
- 8- Due to fuel composition and operational conditions, hard layers of soot and sulfur formation may be observed. As these layers are dangerous for boiler materials, they must be cleaned as soon as possible. Cleaning with boiler tube brush shall not be enough for hard layers, a special electric cleaning equipment or movable head cleaning machines can be used.
- 9- Grease oil like molykote must be applied on bolts and nuts before closing the front doors, after cleaning.
- 10- There is one hand hole at the back of the boiler. This is a DN100 or bigger flanged connection port. To inspect water side of the boiler this hand holes can be used. Before opening the handhole the steps described in "5.2 - Shutdown & Discharging" section must be completed. Prepare gaskets before opening the hand hole and change the gaskets each time you open this port. Bottom blowdown valve may be connected to this nozzle, in such case the bottom blowdown valve must be disassembled to remove the DN100 flange. The mud and scale at the bottom of the boiler must be cleaned and washed through these handholes.
- 11- Manholes are also used to observe scale formation and sediments on the water part of the boiler. For interior inspection of the boiler Manholes are used. Manholes are heavy accessories. The operator must be very careful during handling these manhole covers. The manhole cover's weight is approximately 30-40 kg. The gasket of these manholes is special. Before attempting to open a manhole be sure to prepare at least 2 spare gaskets. Before opening the manholes, the steps described in "5.2 - Shutdown & Discharging" section must be completed. The doors/covers of manholes must be produced to face the sides of the manhole port with the letting no cavity. Before placing the gaskets, gasket's sockets must be cleaned up and the gaskets must be pulled in the sockets. The space between gaskets and their sockets must be equal in every side. Gaskets of the doors must be tightened equally and gradually. High quality gaskets with graphite or the gaskets advised by Akkaya Technical Service must be used.
- 12- Even just very thin layer like 1 mm of scale/lime on the water side of the boiler, not only drops the efficiency but also causes extra heating of the materials. It must be cleaned with pressurized water. If you fail to get rid of all the lime, chemicals can be used for cleaning.
- 13- If proper water is fed to the boiler, lime formation on the heating surfaces will not occur.
- 14- Feed water must always be checked for oil content. Oil content in feed water must strictly be avoided.

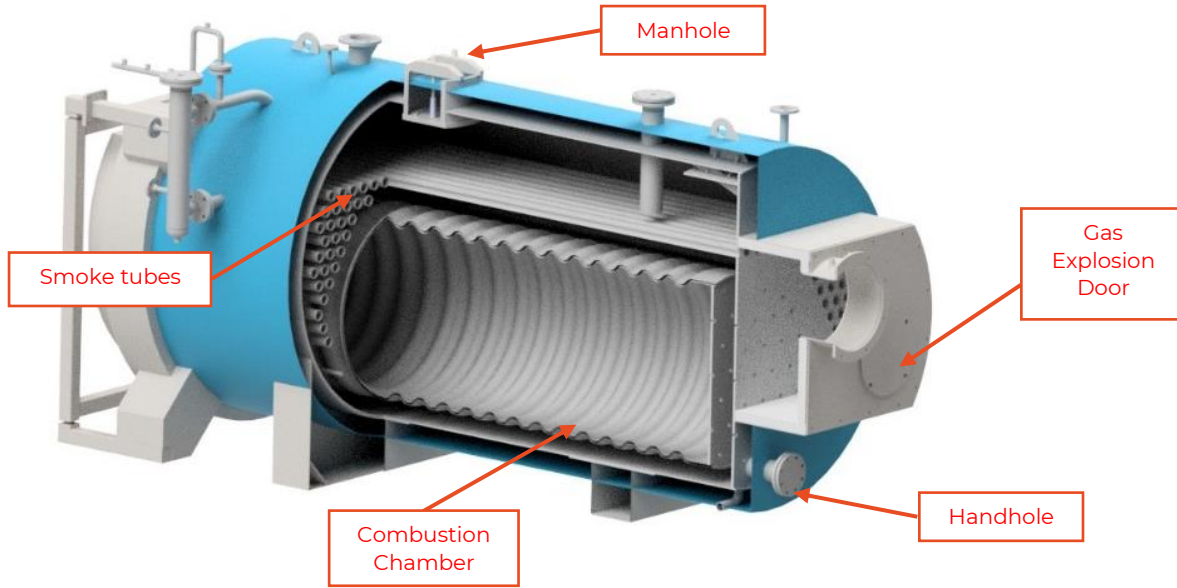

5.5 Boiler Inspection and Cleaning Zones

5.6 Protecting The Non-Operating Boiler



If the boiler is not going to be used longer than one week, the following process must be carried out to prevent rust and corrosion formation.

- 1- Smoke pipes and smoke side of mirror plates must be cleaned at a boiler temperature of approximately 40 ° C.
- 2- All smoke surfaces of the boiler must be cleaned with oil to prevent direct air contact.
- 3- The air at the smoke side of the boiler must be dry. This can be achieved by putting air drier chemicals inside the boiler.



When the boiler is out of service, corrosion formation can take place faster than an operating boiler. If there is water with a little alkali content in the boiler, rust and corrosion occurs quickly. If precautions are not taken, corrosion will keep on forming, even when the water is discharged completely. Corrosion can only be prevented if there is NO water in the boiler and the oxygen attack to the metal surfaces are prevented when it is NOT operating.

- 4- After the boiler cools down, water must be filled in with necessary chemical addition.
- 5- The phosphate content of the boiler water can be increased by mixing 600 g tri sodium phosphate per m³.
- 6- ~700 g hydrazine and ~150-250 g sodium sulfate can be added to the boiler water to prevent rust and corrosion.
- 7- Water must be fed to the boiler until water comes out from the valve at the highest point of the boiler (air vent valve or connection nozzle under the vacuum breaker). This is done to be sure there is no air left inside the boiler. Then all the valves on the boiler must be fully closed.
- 8- To prevent freezing, the boiler room temperature must be kept above +4 ° C.
- 9- Before re-operating the boiler, chemical added water must be gradually discharged by making blow down.
- 10- After the chemical added water is completely discharged, the boiler must be filled with normal boiler water until normal level is reached.



If the boiler will not be operated for a period more than 3 months, it must be kept free of water. The following steps must be followed.

- 1- Boiler water must be discharged through blow down valve when it is at low pressure (approximately 0,2barG) and still hot. By this way some amount of the muds or dirt at the bottom of the boiler can be drained.
- 2- After the water is discharged, safety valve must be opened to discharge all the steam.
- 3- All inspection ports (manholes and handholes) must be opened and controlled to see whether inside of the boiler is dry or not. It must be dried if it is still wet.
- 4- The pots of diminished lime and calcium chloride must be put in the boiler. These pots must be discharged in every three months.
- 5- To eliminate the rest of oxygen in the boiler, a firing pot with oil-lamp and firewood must be placed in the boiler.
- 6- All inspection ports and valves must be closed.
- 7- Holes, flanges, and valves must be tightly closed and double checked to prevent leakage.

5.7 Feed Water And Boiler Water Quality

It is essential to eliminate risks at feed water, steam lines and boiler by continuous boiler feed water treatment. The possible risks and their results are:

- 1- Lime or scale formation on the boiler surface because of water hardness. This may cause safety failures, heat transfer difficulties, efficiency loss, heat deposition and non-operating boiler.
- 2- Thin layers of oil and organic material on the boiler's heating surface can cause excessive heat in the boiler.
- 3- Free oxygen and free carbon dioxide weaken the boiler material and cause corrosion.
- 4- High organic components quantity causes foam formation, and this foam carries organic substances. When evaporation starts particulate deposition and transfer will occur in the pipelines and equipment which will end up with blockings and breakdowns.



Proper water according to EN12953-10 must be used for generating steam.

Continuous control of Feed Water and analysis:

- 1- Date of taking sample of feed water must be recorded. It will be enough to take sample daily from where the water components' amount and conditions are stable.
- 2- The sample must be taken just after blowdown, and it must be analyzed under pressure by cooling.
- 3- The sample pot must be clean. It must be shaken with the sample before filled in.
- 4- At least 2 liters of sample water must be filled in the pot.
- 5- Daily report of the analysis carried out must be written and archived.
- 6- Below specifications must be measured and recorded in the analysis report
 - Color
 - Smell
 - Nitrite ratio
 - Ammonia ratio
 - Hardness
 - pH value
 - Sediment
 - Conductivity
 - Organic Materials
 - Sulfur
 - P Alkaline
 - M Alkaline
 - Free Chlorine
 - Magnesium
 - Chlorine
 - Ferro
 - Silica
 - Calcium
- 7- Water must be clean and purified from mechanical dirt.
- 8- The total amount of manganese mustn't exceed 0,05 mg/kg.
- 9- The total amount of Ferro mustn't exceed 0,2 mg/kg.



- 10- The specifications of the water softening system shall be determined according to the water properties.
11- Filters for Mangan and Ferro protection must be installed.
(EN 12953-10 must be studied for detailed information)



MANUFACTURER'S GUARANTEE SHALL BE VALID IF ONLY CUSTOMER CARRIES OUT THE RESPONSIBILITY TO PROVIDE PROPER FEED WATER CONDITIONS.

APPENDIXES



APPENDIX 1 -SAMPLE DAILY CONTROL CHART

Observation and testing	Clauses Ref. EN 12953-6	Daily *	1 month	3 months	6 months	12 months	Remarks
Safeguards against excessive pressure (safety valves)	4.1	O			T		-
Water level indication	5.1	T					Compared with limiters and controls
Drain and blow-down devices	4.6	T					-
Valves	5.3	O			T		As per manufacturer's operating instruction
Feed water control	5.5	O			T		-
Low water protection	5.6.1	O	T				Functional check by lowering the water level to the switching points
Steam pressure and temperature indication	5.2	O					Compared with limiters and controls
Pressure limitation	5.6.2	O	T				Functional check by increasing the pressure to the switching points
Temperature limitation	5.6.3	O	T				
Devices for water quality protection	4.8	O	T (1)		T(2)		(1) Comparison of the measured values with the reliable samples (see 4.7.2 of EN12953-6) (2) Performed by a suitably qualified and competent person
Protective device	4.3	O			T(3)		(3) Electrical and mechanical testing performed by a suitably qualified and competent person
Pressure parts (pipes, inspection openings, flanges, gaskets, joints...)			O				
Pressure controller and temperature controller	4.4.1	O			T		
Feed water supply	5.4	O		T			
Water quality	4.7	T(4)					(4) see EN 12953-10:2003
Energy Supply	4.4	O				T(5)	Performed by a suitably qualified and competent person as per operating instruction but not less than once a year.

(O) Observation of abnormal noises, smells or other noticeable factors.

(T) Checking and/or testing the functional behavior of equipment parts, including observation.

* In the standard it is written as 72 hours, Akkaya Boilers strictly recommends these controls to be done DAILY.

A daily control chart must be recorded and kept by the operator of the boiler. If the daily controls are not done and recorded properly manufacturer's guarantee will be invalid. A safe and efficient operation of the boiler can be sustained by making these controls.

APPENDIX 2 - WATER QUALITY REQUIREMENTS

ICS 13.060.25; 27.060.30;
27.100

TS 377 10
EN 12953-10 JANUARY 2006

Table 5-1 — Feedwater for steam boilers (except attemperator spray water) and hot water boilers				
Parameter	Unit	Feed water for steam boilers		Feed water for warm water boilers
Working pressure	bar (= 0,1 MPa)	> 0,5 - 20	> 20	Total interval
Appearance	-	clear, free from suspended solids		
Direct conductivity 25 °C	µS/cm	not specified, only guide values relevant for boiler water see table 5-2		
pH value at 25 °C*	-	> 9,2**	> 9,2**	> 7,0
Totalhardness (Ca + Mg)	mmol/L	< 0,01***	< 0,01	< 0,05
Iron (Fe) concentration	mg/L	< 0,3	< 0,1	< 0,2
Copper (Cu) concentration	mg/L	< 0,05	< 0,03	< 0,1
Siliciumdioxide (SiO ₂) concentration	mg/L	not specified, only guide values for boiler water relevant, see table 5-2		-
Oxygen (O ₂) concentration	mg/L	< 0,05****	< 0,02	-
Oil/ grease concentration (see EN 12953-6)	mg/L	< 1	< 1	< 1
Organic substances (as TOC) concentration	-	See Footnote *****		

* pH must be in between 8,7 - 9,2 for copper alloys.

** With softened water pH value > 7,0 the pH value of boiler water according to table 5-2 should be considered.

*** At operating pressure < 1 bar total hardness max. 0,05 mmol/ shall be acceptable.

**** Instead of observing this value at intermittent operation or operation without deaerator if film forming agents and/or excess of oxygen scavenger shall be used.

***** Organic substances are generally a mixture of several different compounds. The composition of such mixtures and the behaviour of their individual components under the conditions of boiler operation are difficult to predict. Organic substances may be decomposed to form carbonic acid or other acidic decomposition products which increase the acid conductivity and cause corrosion or deposits. They also may lead to foaming and/or priming which shall be kept as low as possible.

ICS 13.060.25; 27.060.30;
27.100

TS 377-10
EN 12953-10 JANUARY 2006

Table 5-2 — Boiler water for steam boilers and hot water boilers					
Parameter	Unit	Water for steam boilers			Boiler water for hot water boilers
		Feed water direct conductivity > 30 µS/cm		Feed water direct conductivity 30 µS/cm	
Working pressure	bar (= 0,1 MPa)	> 0,5 - 20	> 20	> 0,5	total range
Appearance	-	clear, no stable foam			
Direct conductivity at 25 °C	µS/cm	< 6000 - (a)	Şekil 5.1-(a)	< 1500	< 1500
pH value at 25 °C	-	10,5 to 12,0	10,5 to 11,8	10,0 to 11,0 (b,c)	9,0 to 11,5 (d)
Composite alkalinity	mmol/L	1-15 (a)	1-10 (a)	0,1 to 1,0 (c)	< 5
Silica (SiO ₂) concentration	mg/l	pressure dependent, according to figure 5-2			-
Phosphate - PO ₄ (e)	mg/l	10 to 13	10 to 30	6 to 15	-
Organic substances	-	see footnote (f)			-

a- With superheater consider 50 % of the indicated upper value as maximum value.

b- Basic pH adjustment by injecting Na₃PO₄, additional NaOH injection only if the pH value is < 10.

c- If the acid conductivity of the boiler feedwater is < 0,2 Na + K concentration is < 0,010 mg/l, phosphate injection is not necessary. Under the conditions AVT (all volatile treatment, feedwater pH 9,2 and boiler water pH 8,0) can be applied, in this case the acid conductivity of the boiler water is < 5

d- If non-ferrous materials are present in the system, e. g. aluminium, they may require lower pH value and direct conductivity, however, the protection of the boiler has priority.

e- If coordinated phosphate treatment is used; considering all other values higher PO₄-concentrations are acceptable (see also clause 4).

f- See e in table 5-1.

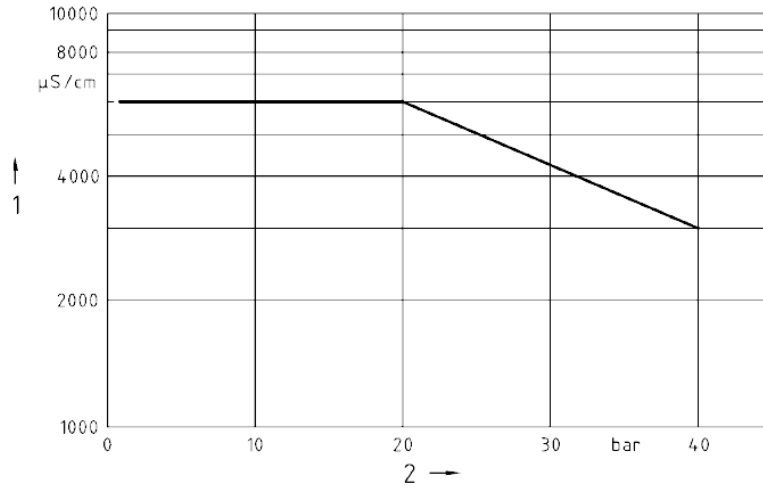

1: Direct Conductivity

2: Operating Pressure

Chart 1.1 Maximum acceptable direct conductivity of the boiler water dependent on the pressure; feedwater direct conductivity $\geq 30\mu\text{S} / \text{cm}$

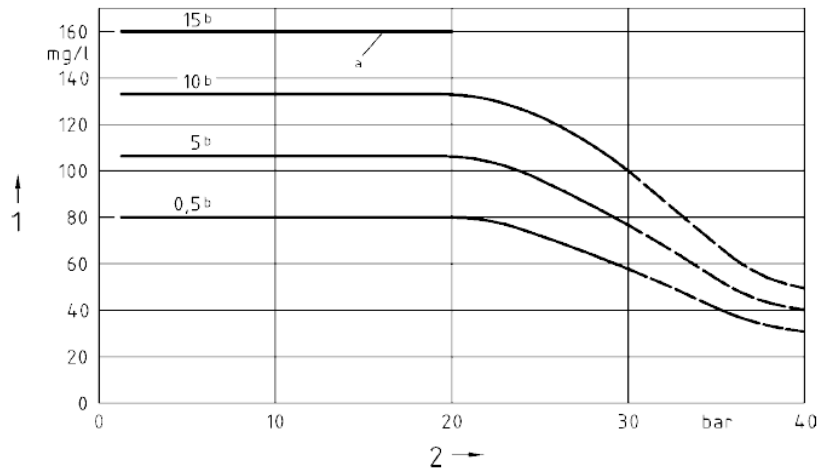

1: Maximum silica content

2: Operating pressure

a) This level of alkalinity is not permissible ≥ 20 bar

a) Alkalinity in mmol / l

Chart 1.2 Maximum acceptable silica content (SiO_2) of the boiler water dependent on the pressure

APPENDIX 3 - DIMENSION TABLE OF KBB - E MODEL BOILERS

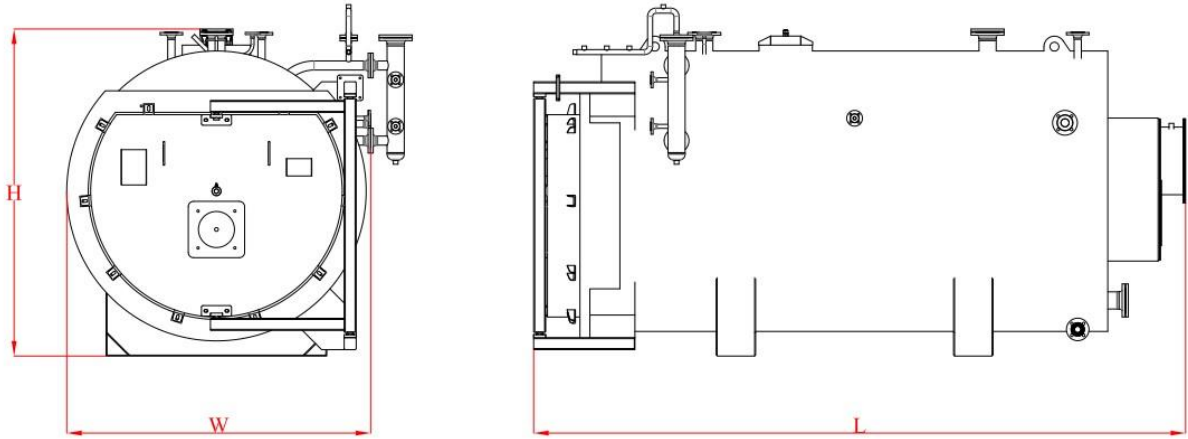

Model	Maximum Steam Capacity F&A 100 ° C (kg/h)	Maximum Heat Capacity (kcal/h)	L (length) (mm)	W (Width) (mm)	H (Height) (mm)	Weight (kg) *
KBB 300	300	180.000	1950	1275	1495	1500
KBB 500	500	300.000	2500	1275	1495	1800
KBB 750	750	450.000	2750	1400	1620	2400
KBB 1000	1000	600.000	3350	1400	1620	2700
KBB 1250	1250	750.000	3400	1550	1770	3200
KBB 1500	1500	900.000	3700	1550	1770	3500
KBB 2000	2000	1.200.000	3255	1950	2170	4600
KBB 2500	2500	1.500.000	3800	1950	2170	5200
KBB 3000	3000	1.800.000	4400	1950	2170	6000
KBB 3500	3500	2.100.000	4250	2200	2420	7300
KBB 4000	4000	2.400.000	4850	2200	2420	8300

*6 bar & empty W/O accessories. Akkaya keeps the right to make modifications and changes in the design and dimensions. For the exact dimensions and design information of your boiler please refer to the technical file provided by Akkaya.

APPENDIX 4 - SYSTEM ACCESSORIES AND AUXILIARY EQUIPMENT EXPLANATIONS

The accessories and auxiliaries explained here may be different than the configuration you have purchased. To be sure about your equipment scope please refer to P&ID and item list provided to you by Akkaya.

APPENDIX 4.1 Burner



Figure Ap. 4.1 Burner on the Boiler

According to the fuel type, KBB model boilers must be equipped with a proper capacity burner as indicated in each models' technical specification table. KBB models can be fired with natural gas, biogas, diesel, heavy fuel oil or biofuel burners. Consult to burner's manufacturer user manual for details.

For modulating burner systems, the boiler pressure set value may need to be entered separately both on the boiler control panel and on the burner controller according to the control system design.

APPENDIX 4.2 Steam Exit Valve

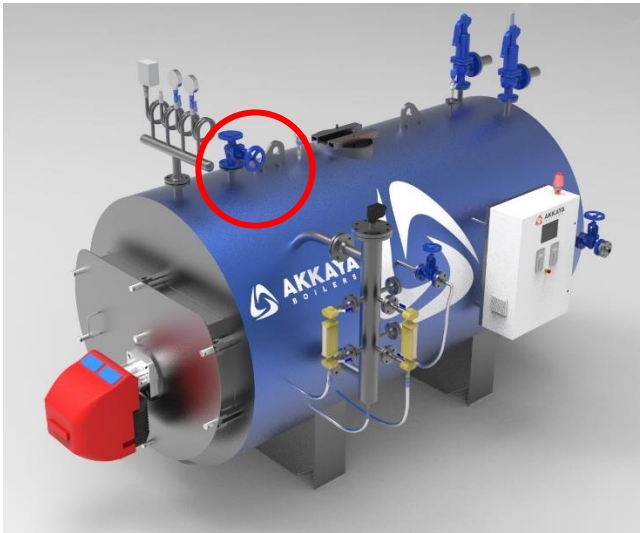

Figure Ap. 4.2 Steam Exit Valve Position on The Boiler

Main steam outlet valve is selected according to the operating pressure. The main steam discharge pipe must have the same dimension with this valve.

APPENDIX 4.3 Bottom Blowdown & Drain Valve Group

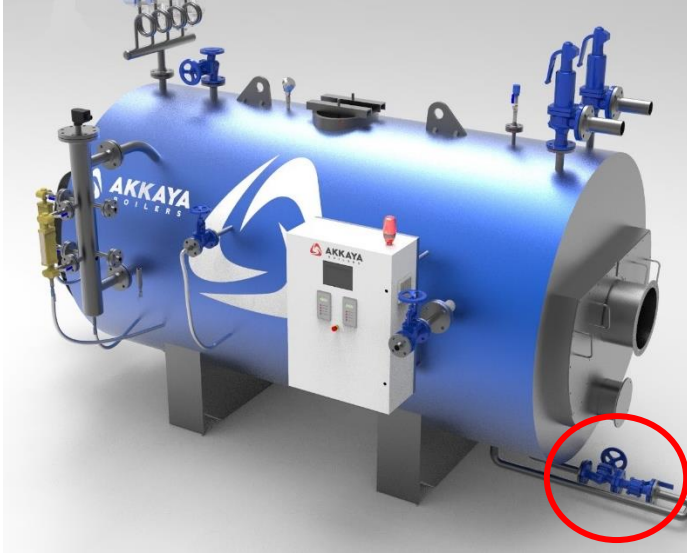

Figure Ap. 4.3.1 Bottom Blowdown Valve

Bottom blowdown valve is used for removing mud, sediment, or dirt from the boiler, by draining some of the boiler water at certain intervals, from the bottom.

This valve can be a manual ball valve or an Automatic Bottom Blowdown Valve. In most cases 3 seconds of blowdown in every 8 hours is recommended. The blowdown period and duration totally depend on the operation conditions. There is a blowdown shutoff valve and a by-pass valve in some systems. For the connection details please refer to P&ID and item list.

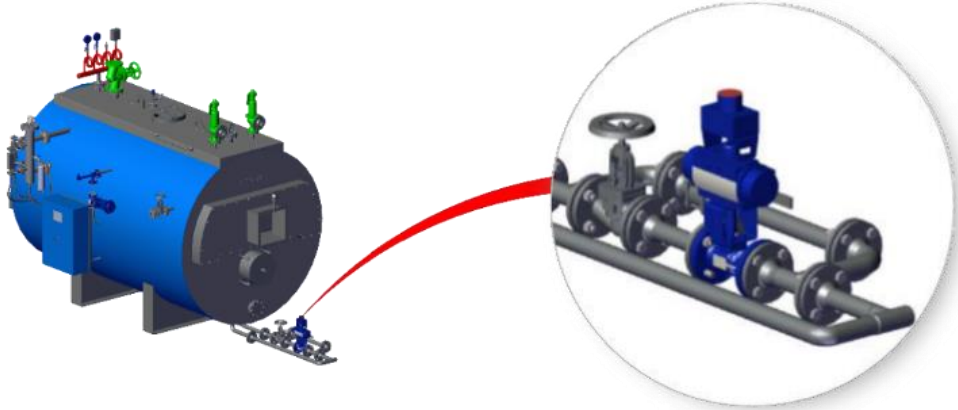

Figure Ap.4.3.2 Automatic Bottom Blowdown System

Solid substances accumulation in boilers (e.g. stone and mud) is caused by some impurities and corrosive substances contained in water. Examples of water impurities are dissolved calcium, magnesium chloride, sulfate, and silicon. Water impurities can be found in condensate and boiler feed water. As a result of corrosion, some substances are also carried with the condensate and feed water. Examples of corrosive substances are iron and copper.

Such accumulations cause efficiency loss, a decrease in productivity, and more importantly overheating. Overheating may result with metal annealing and pipe explosion. Automatic blowdown system is used to purge these substances from the boiler automatically at certain intervals without human interaction.

APPENDIX 4.4 Surface Blowdown Valve and System

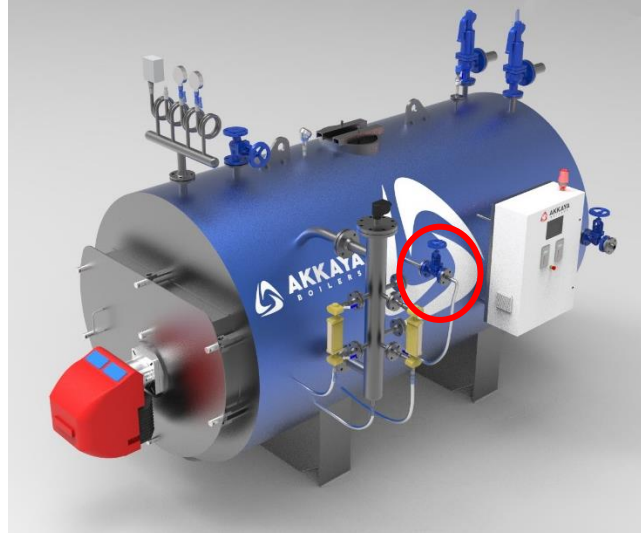

Figure Ap.4.4.1 Surface Blowdown Valve

Surface blowdown valve is used for regulating the salt concentration and conductivity of the boiler water. This valve can be a manual DN20 / DN25 globe valve, or an automatic valve combined with a conductivity sensor and a controller.

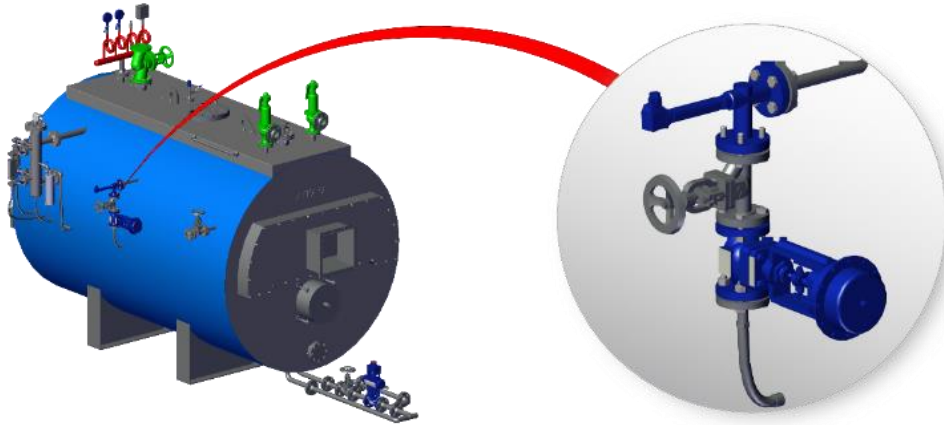

Figure Ap.4.4.2 Automatic Surface Blowdown System

The automatic surface blowdown system automatically measures the amount of undissolved material via conductivity of water to optimize the surface blowdown interval.

This system minimizes the amount of blowdown to ensure that the amount of chemicals used remains at acceptable levels and reduces energy loss to a minimum level. It reduces the cost of water treatment, fuel consumption and heat loss by a considerable amount.

APPENDIX 4.5 Sample Cooler

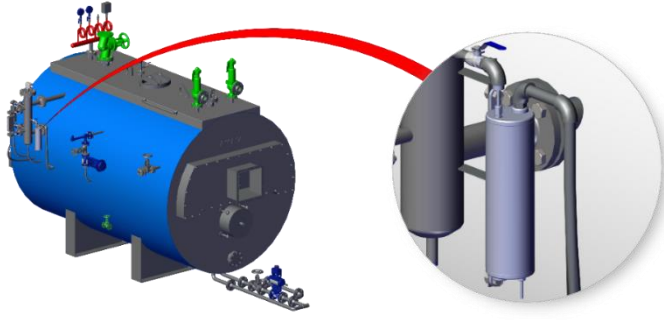
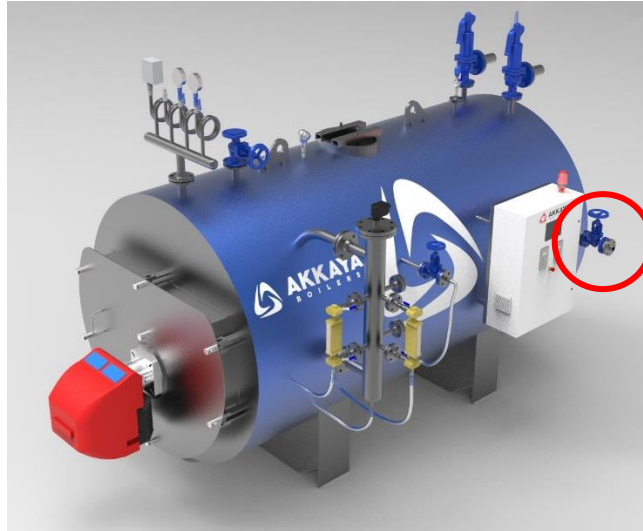

Figure Ap. 4.5 Sample Cooler

The sample cooler is a small heat exchanger that uses cold water to cool the hot water sample taken from the boiler. Please refer to the P&ID and sample coolers user manual for installation and operation instructions.

APPENDIX 4.6 Boiler Water Inlet Valve & Check Valve



Şekil Ek 4.10 Basınç Şalterleri

The boiler water inlet valve allows water to enter the boiler. The valve position must be open during normal operation.

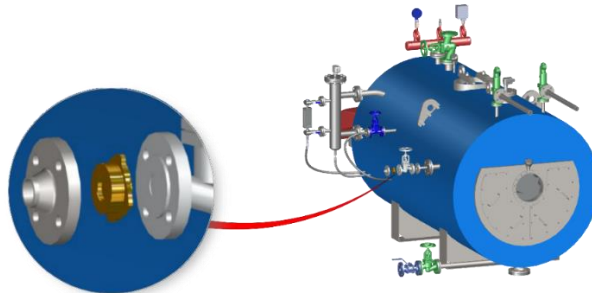

Figure Ap. 4.6.2 Boiler Water Inlet Check Valve

Check valve is used to prevent steam back flow to the feed water pump line.

APPENDIX 4.7 Safety Valves

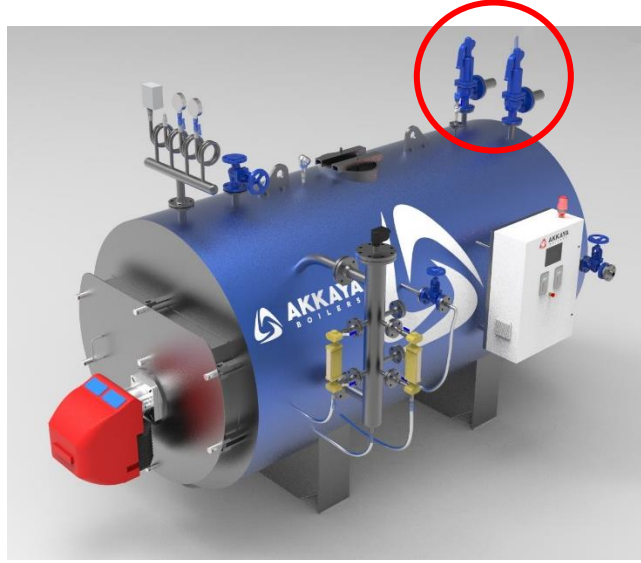

Figure Ap. 4.7 Safety Valves

Safety valves must be fully-lift type and, the diameter is determined according to the operating pressure and steam capacity of selected boiler model. Although one piece is accepted by the norms it is strictly recommended to use two safety valves in boiler configurations. Safety valve must be opened to any safe place out of the boiler room by a pipe with same or bigger diameter with the valve's exit dimension. Certainly, there mustn't be any valve connected to safety valves' inlet or exit.

Safety valve must be chosen to discharge the steam when boiler is at its full load exceeding 10% of maximum operating pressure. Safety valves set value must be adjusted to a value about 10% higher than boiler's maximum operating pressure. Set value must never be higher than boiler's design pressure. All valves must be CE certificated. EN12953-8 norm must be followed for selection of the proper safety valve.

If there is a risk of freezing in the discharge line, precautions must be taken.

APPENDIX 4.8 Automatic Boiler Water Level Controllers

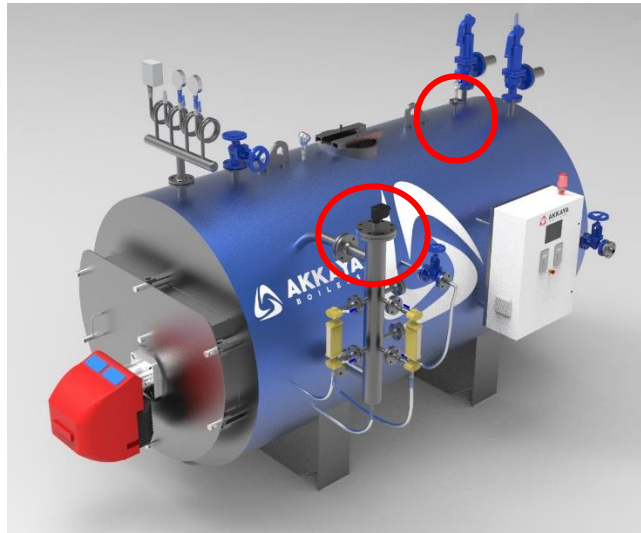

Figure Ap.4.8.1 Boiler Automatic Water Level Controller

Water level controller is used for controlling the level of the boiler water for high, low (pump on), normal (pump off) and low-low levels. According to the selected configuration a secondary low water level controller, a high-water level controller and a modulating water level controller can be installed in the system additionally.

Minimum two pieces of level controllers must certainly be installed for boiler systems, to provide back-up and constant level control which is vital for a safe operation.

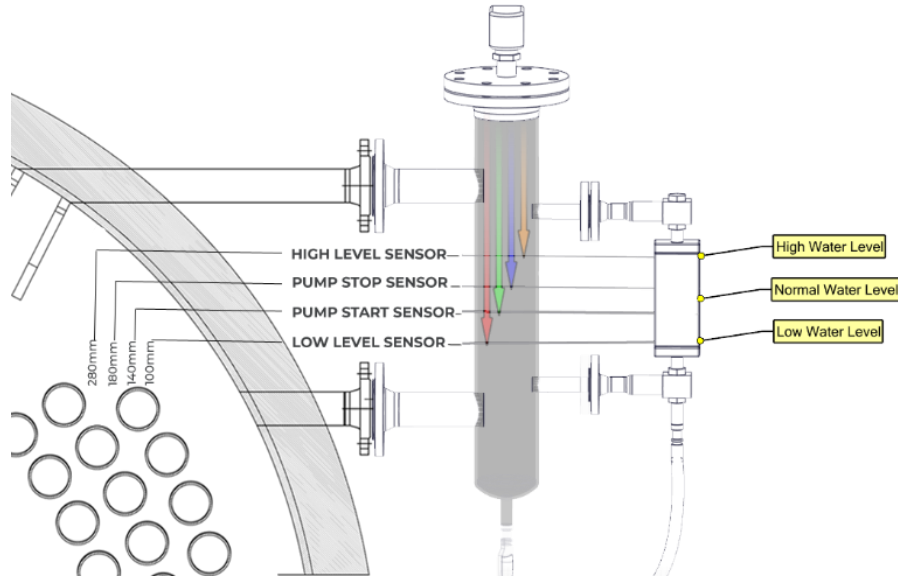

Figure Ap.4.8.12 Automatic Water Level Controller sensor positions

- Low water level sensor is appr. 10 cm above the upper smoke pipe. When the water level reaches this limit, the boiler gives a water low level alarm.
- High water level sensor is appr. 28 cm above the upper smoke pipe. When the water level reaches this limit, the boiler gives a water high level alarm.
- Pump start sensor is appr. 14 cm above the upper smoke pipe. When the water level reaches this limit, the pump starts.
- Pump stop sensor is appr. 18 cm above the upper smoke pipe. When the water level reaches this limit, the pump stops.

For the exact dimensions of the level probes please consult Akkaya Service. Do not try to adjust probe levels without supervision and approval of Akkaya Technical Service.

APPENDIX 4.9 Reflex Glass Boiler Water Level Indicator

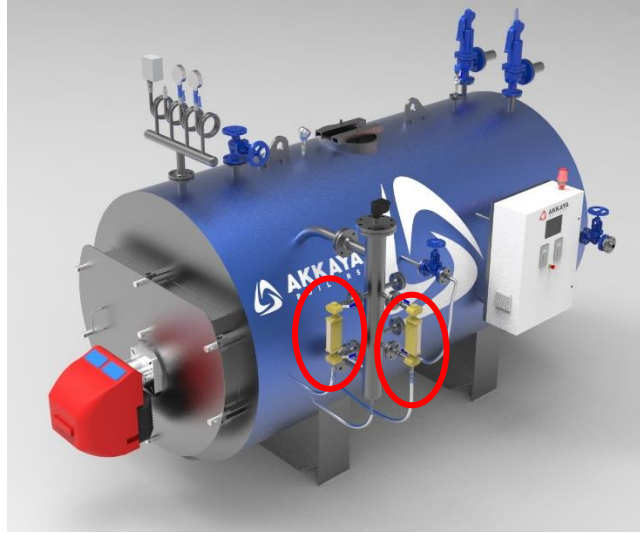

Figure Ap. 4.9 Reflex Glass Boiler Water Level Indicator

There is at least one piece of reflex glass type, level indicator in boiler configuration. The most frequently used models are Reflex Glass types with the dimension 310 mm & 400 mm (these are the distances between connection flanges). Refer to P&ID and item list for the product specifications.

APPENDIX 4.10 Pressure Switches

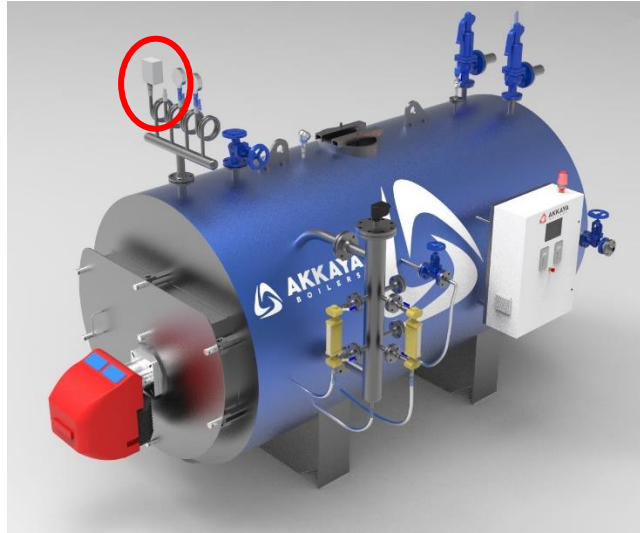

Figure Ap. 4.10 Pressure Switches

At least one pressure switch for alarm and safety must be installed on the boiler. The set value interval of the pressure switches must be proper for the maximum operating pressure of purchased boiler model.

The pressure switches must be connected onto a siphon (or omega) type tube. This prevents the pressure switch from getting harmed by high temperature and sudden pressure hit. Some water is added into the siphon before connecting the pressure switch.

APPENDIX 4.11 Pressure Transmitter

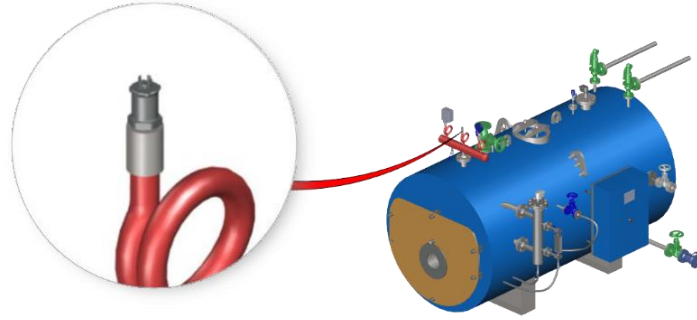

Figure Ap. 4.11 Pressure Transmitter

Pressure transmitter is used to convert the measured pressure to an electrical value (4-20 mA).

Pressure transmitter sends the pressure value information to the main board to regulate the burner's operation.

The pressure transmitters must be connected onto a siphon (or omega) type tube. This prevents the pressure transmitter from getting harmed by high temperature and sudden pressure hit. Some water is added into the siphon before connecting the pressure transmitter.

APPENDIX 4.12 Manometer & Manometer Valves

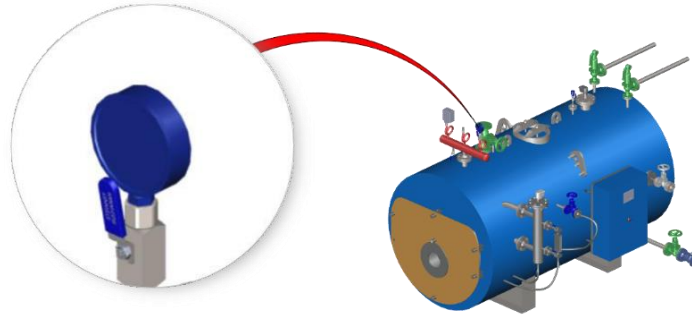

Figure Ap. 4.12 Manometer & Manometer Valves

Manometers with valve is used to observe the pressure of the boiler. The recommended minimum diameter of the manometers is 100 mm. The scale of the manometer must be able to show maximum working pressure of the boiler. A valve with drain outlet is used under the manometer. The maximum operating pressure of the boiler must be red marked on the manometer. The manometers must be connected onto a siphon (or omega) type tube. This prevents the manometer from getting harmed by high temperature and sudden pressure hit. Some water is added into the siphon before connecting the manometer.

APPENDIX 4.13 Boiler temperature control and alarm system (Thermocouple)

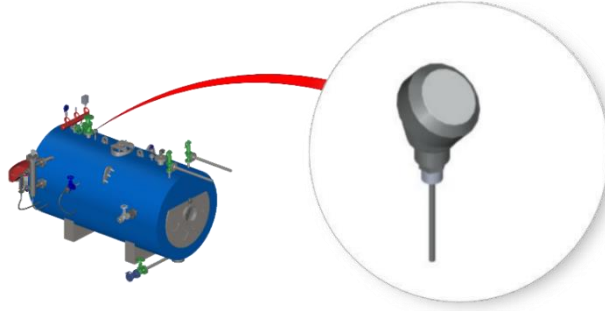

Figure Ap. 4.13 Boiler Temperature Sensor

Akkaya steam boilers' control panel is equipped with a digital heat indicator and alarm system, receiving the heat value by the help of a thermocouple placed on the boiler top. This heat controller is a safety device. It saves the boiler from getting damaged by low or high temperature. For low temperatures (less than 5 °C) there is always a risk of ice formation inside the boiler or inside the control & safety accessories. In such cases this controller shuts down the burner.

For high temperature (at most 10 °C higher than steam saturation temperature at the operating pressure), there is a risk of low water level in the boiler. This is quite hazardous. In this case this controller stops the burner, and it also stops the water feed pumps.

APPENDIX 4.14 Exhaust Gas Temperature Sensor

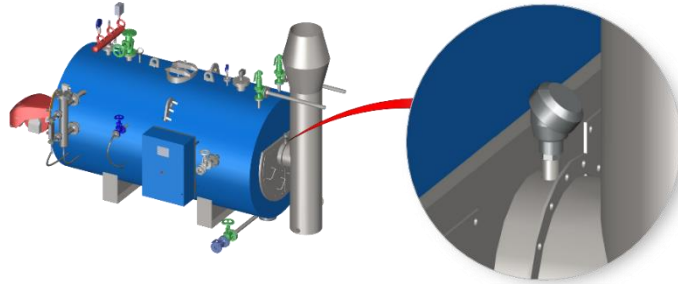

Figure Ap. 4.14 Exhaust Gas Temperature Sensor

Steam boilers' control panel is equipped with a digital heat indicator and alarm system, receiving the heat value by the help of a thermocouple that is placed between chimney and boiler. This heat controller is a safety device.

Received temperature information is used to understand the heat loss from boiler. In case of lime or slag formation inside the boiler, the stack temperature increases. In this case smoke tube cleaning and water parts cleaning must be carried out. Also, low water case can cause high stack temperature. This sensor stops the burner and prevents water pumps from operating if the alarm value is reached.

APPENDIX 4.15 Vacuum Breaker

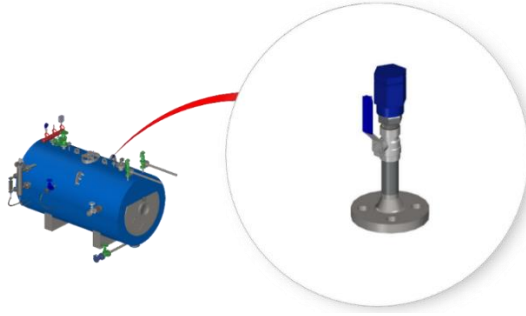

Figure Ap.4.15 Vacuum Breaker

A vacuum breaker is used to prevent vacuum in the boiler. It works like a one-way valve. When the boiler is shut down and steam is cooled inside the boiler, some vacuum starts to form. The vacuum breaker allows sufficient air to enter in the boiler when there is a vacuum. If there is no vacuum breaker on the boiler, vacuum inside the boiler causes water to be sucked through the feed water pumps and a high-water level alarm is received. When the pressure inside the boiler increases, the vacuum breaker closes.

APPENDIX 4.16 Electrical Control Board

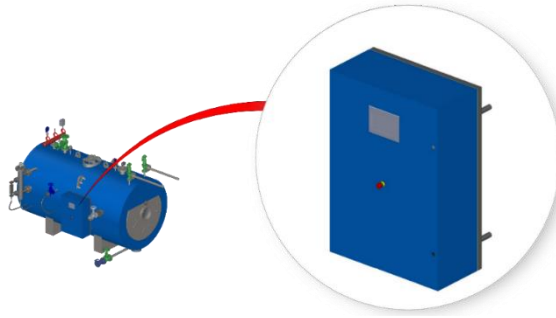

Figure Ap. 4.16 Electrical Control Board

A PLC board is provided in the standard package of KBB steam boilers. The control board contains the boiler operation system, and the safety system controls.

There is an emergency stop button (can be increased in serial connections) to stop the whole operation in case of emergency or unexpected situations.

A hooter connected to board gives an auidal alarm signal in case of safety failures. Also, a flashlight on top of the board gives visual alarm.

A remote connection option is included in the control board by which Akkaya technicians can connect the boiler system remotely if customer provides a cable internet connection to the board.

A separate electrical control board manual and wiring diagram is provided by Akkaya for each purchased boiler.

APPENDIX 4.17 Water Softener



Figure Ap. 4.17 Water Softener

A water softener, at a proper capacity selected for the raw water feed flow rate and water specification. It is necessary to consult to a professional water treatment company for selection and operation. A good water treatment system is essential for a safe and reliable operation of the boiler.

APPENDIX 4.18 Condensate Tank Without Heater

A condensate tank, at a minimum proper volume according to the plant's steam consumption must be installed in the boiler room of steam systems.

Condensate tank is necessary to feed initial water to the boiler by feed pumps and to store the returning condensate from the condensate lines of the consumer plant.



The closed cycle of the boiler system must be completed by a condensate tank to circulate a certain amount of hot, decalcified, boiler water for increasing the fuel consumption efficiency and boiler operational life.

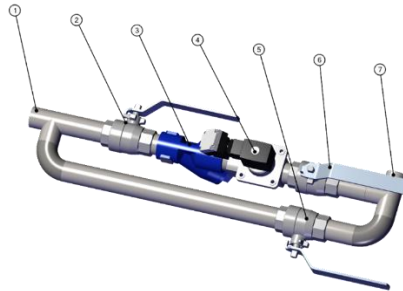

Figure Ap.4.18.1 Condensate Tank Water Inlet Solenoid Valve Group

Water is fed in condensate tank with automatic solenoid valve group. Solenoid valve is supplied as a group including a strainer and inlet, outlet and bypass valves. If there is a damage on solenoid valve, it can be changed or repaired easily by closing inlet and outlet valves. Water feeding can be provided on bypass line during maintenance.

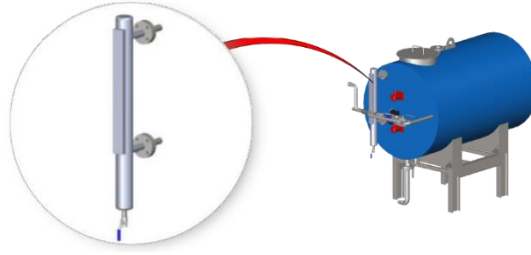

Figure Ap. 4.18.2 Magnetic Level Indicator

There must be at least 1 water level indicator on the condensate tank. These level indicators help us to see the feed water level in the condensate tank.

Water level controller is used for controlling the level of the condensate tank.

Condensate tank drain valve is used for draining the water inside the condensate tank.

APPENDIX 4.19 Pre-Heated Condensate Tank (Atmospheric Deaerator)

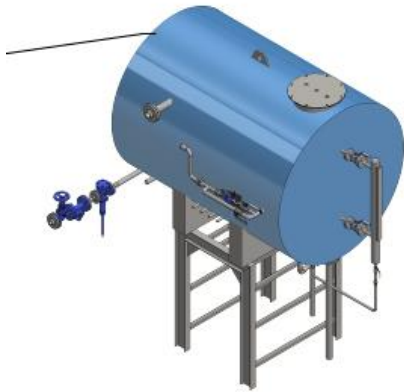

Figure Ap. 4.19 Atmospheric Deaerator

Akkaya Pre-Heated Feed Water Storage (Condensate) Tank (Atmospheric Deaerator) system is designed to remove the dissolved gases and oxygen from the boiler feed water by appropriately mixing condensate, flash steam, and cold feed water. Gases soluble in feed water are carbon monoxide, oxygen, hydrogen sulfide, and methane. Except nitrogen, which does not cause such problems due to chemical features, the existence of all other gases must be avoided for reasons:

- a) CO_2 lowers pH and makes water aggressive towards refractories and metal surfaces.
- b) O_2 causes corrosion of metal surfaces that are in contact with water.

At least partial removal of gases can be accomplished by two methods:

- 1- Physical method: Solution of gases and eliminating them from water
- 2- Chemical method: Reagents that are added to gases dissolved in water.
- 3- Thermophysical method: Removing gases from water based on a solubility-temperature correlation. The oxygen content in the feed water at an absolute pressure of 1 bar (atmospheric pressure) and a temperature of 90°C is less than 0.2 mg/l , which is permissible.

In Akkaya Atmospheric deaerators thermophysical method is used. The maximum water temperature goes up to $90\text{-}95^\circ\text{C}$ and degassing is carried out by the help of a suitable sized deaerator.

The main elements of the Pre-Heated Feed Water Storage (Condensate) Tank system are pre-heated storage tank, steam injection group, and water inlet solenoid group.

Steam coming from the boiler system to the pre-heated storage (condensation) tank first reaches the control valve (thermal closing valve) through the steam spray pipe (sparge pipe). The operating temperature of the tank is adjusted mechanically with this valve. The steam increases the temperature of the water and so feed water free of dissolved gases at a temperature of $90\text{-}95^\circ\text{C}$ is obtained.

APPENDIX 4.20 Condensate Tank with Spray Scrubber Type Compact Deaerator



Figure Ap. 4.20.1 Condensate Tank with Spray Scrubber Type Compact Deaerator

Akkaya Compact Deaerator system is designed to remove the dissolved gases and oxygen from the boiler feed water by properly mixing condensate, flash steam and cold feed water. The dissolved oxygen (O_2) ratio in the boiler feed water must be less than 0.05 mg / l and the amount of molten carbon dioxide (CO_2) must be 0 (zero).

The main elements of Akkaya Spray Scrubber Deaerator system are deaerator tank, deaerator dome, steam injection, pressure reducing valve and water inlet solenoid valve.

Water is fed to the deaerator tank through the inlet feed water connection. There are spray nozzles in the deaerator tank to prevent the steam and gases from mixing with water. Spray nozzles help water to pour into the tray in a pulverized way. Water particles are sprayed at an angle of 90° and as very small particles. By this way water is easily separated from the oxygen and carbon dioxide in it.

Steam is injected to the deaerator tank with sparging type pipes. The steam in the atomization zone heats the sprayed and degassed water. As steam increases the temperature by encountering the sprayed water flowing into the tray, feed water free of dissolved gases at a pressure of 0.2-0.3 bar and at $102^\circ C$ temperature is obtained. Undissolved gases are thrown into the atmosphere through the vent valve on the tank. There is also a steam trap group in the tank to eliminate the overflows that may occur at the water level.

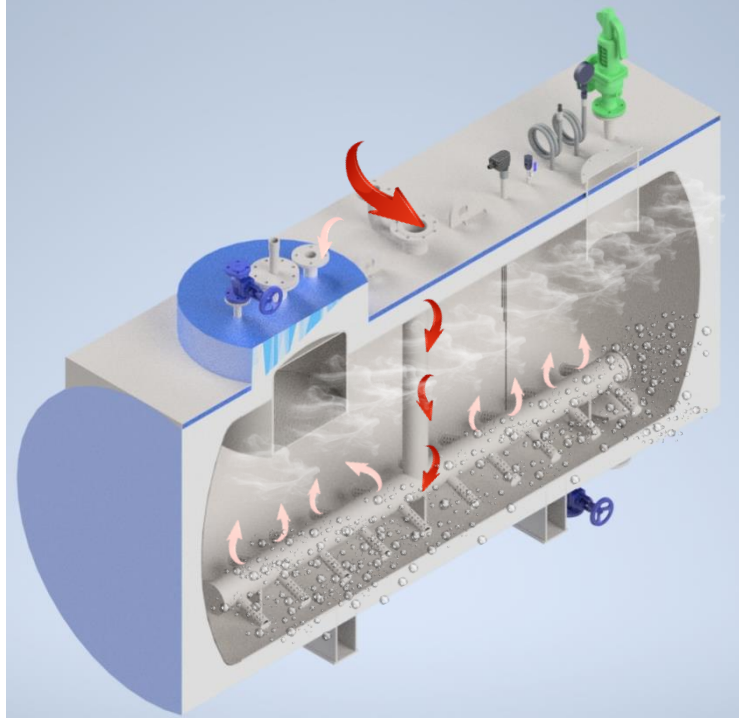

Figure Ap. 4.20.2 Spray Scrubber Deaerator Working Principle

Steam coming from the injection outlet line on the boiler, first goes to the pressure control valve. Here, steam pressure is reduced to approximately 0.4 bar. The low-pressure steam is finally sent to a temperature controlled proportional control valve on the line.

Pressure control valves are used to reduce the pressure from the boiler operating pressure to the desired value. Therefore, the outlet pressure of the pressure control valve must be set to max. 0.4 bar.

A safety valve is installed in the outlet line of the steam pressure reducing valve. Its set pressure must be 0.5 bar. If there is still excess pressure after pressure reduction, due to incorrect reduction and / or damaged parts, the safety valve will release the vapor that is 0.5 bar or more.

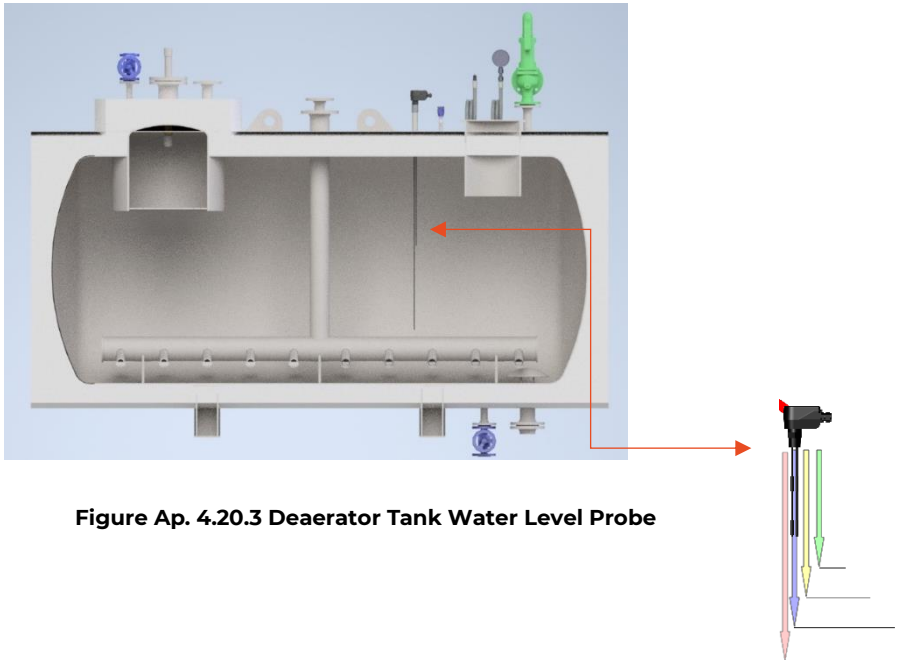





Figure Ap. 4.20.3 Deaerator Tank Water Level Probe

The water level probe on the deaerator tank consists of 4 conductive rods. These conductive rods send the running or stopping signals from the deaerator tank and boiler feedwater pump to the control panel. Probe sizes are shown in detail in the figure above. (Dimensions are from flange to rod end.)

-  The probe rod indicated by a green arrow indicates the limit value for the high-water level.
-  The probe rod indicated by the yellow arrow indicates the limit value of the pump stop level.
-  The probe rod indicated by the blue arrow indicates the limit value of the pump start level.
-  The probe rod indicated by a red arrow indicates the value for low water level.

APPENDIX 4.21 Feed Water Pump Group

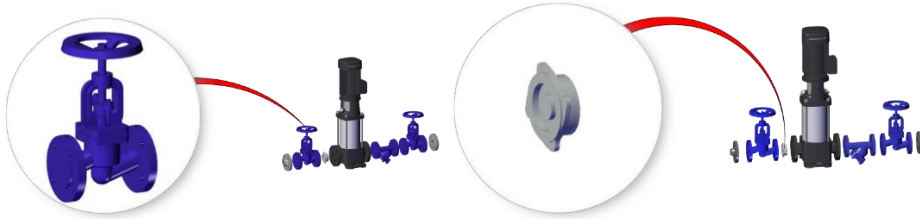

Figure Ap. 4.21.1 Pump Inlet-Outlet Valves Figure Ap. 4.21.2 Pump Check Outlet Valve

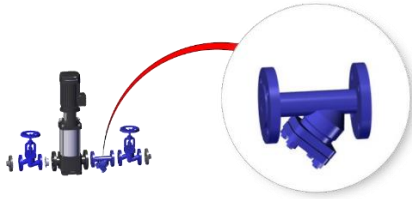

Figure Ap. 4.21.3 Pump Check Inlet filter

Boiler feed water pumps are used to feed boiler with water through water inlet valve with water taken from feed water tank/deaerator tank outlet flange. Pumps are usually selected as multi-stage, vertical, centrifugal type. Pump and valve sizing is made according to the boiler's steam production capacity and operating pressure. Volumetric flow ratio and head of pump is selected properly higher than boiler steam capacity and operating pressure. Inlet and outlet connections must be made by considering suction and compression side dimensions of pump. Internal sealing of pumps and gaskets between group elements need to be controlled periodically since their working temperature is generally 90 ° C -120 ° C.

APPENDIX 5 -BOILER CONTROL SYSTEM STANDARD ALARMS EXPLANATIONS

Boiler Water Low Level

This alarm turns on when the water inside the boiler is at a lower level than normal set level. When boiler gets into alarm position, burner stops. To operate the boiler again, MANUAL RESTART must be done. The causes of low water level must be investigated. (Faulty feed pump, lack of water in the feed water tank, blocked water feed line... etc.)

Boiler Water High Level

This alarm turns on when the water inside the boiler is at a higher level than normal set level. In this case the feed water pump does not operate, burner stops, and MANUAL RESTART is necessary. Water must be discharged through the blowdown line until the water level inside the boiler decreases to normal level. Increase in the water volume due to the initial heating up may cause this alarm to turn on. Another reason maybe, faulty operation of water level controllers.

Low Temperature Alarm

This alarm turns on when the water temperature inside the boiler comes close to the freezing point (+5°C). In this case pumps and burner do not operate. After the ambient temperature rises and the ice inside the boiler is checked and safely eliminated, boiler can be operated by MANUAL RESTART.

High Temperature Alarm

Boiler high temperature alarm turns on in cases where the saturated steam temperature inside the boiler exceeds the theoretical steam temperature at operating pressure (saturation temperature+10o C). In this case pumps and burner do not operate. Boiler can be operated again by MANUAL RESTART after the temperature is decreased. Lack of water in the boiler may cause this situation. It must strictly be investigated by the authorized personal / service.

High Pressure Alarm

This alarm triggered by the pressure switch or by the pressure transmitter installed on the boiler. It turns on when the system pressure is higher than the pre-set value. In this case burner stops automatically. To operate the boiler again, after the pressure decreases to normal value, MANUAL RESTART must be done.



In high pressure cases burner automatically stops. But if the pressure continues to increase, safety valves automatically open and steam is discharged until the pressure decreases to set value and alarm turns-off.

Burner Error/ Failure

Signal indicates that there is a fault in burner operation. Boiler must be re operated only after the fault is investigated and eliminated by an authorized service or staff.

Feed Water Pump & Solenoid Operation

-Boiler 1. Feed Water Pump On / Off must be "on" in normal operation.

-Boiler 2. Feed Water Pump On / Off must be "off" in normal operation as stand-by.

In cases where "pump error" signals are on, faulty pump must be stopped manually and other one must be operated. The pump error signal comes from the motor protection thermic switch. It must be reset from thermic relay.

-Feed Water Tank Solenoid Valve must be at "on" position in normal operation.

Hooter/ Siren Shutdown

It is for shutting down the voice of boiler controls. It only shuts down the voice alarms, signals continue to function.

Manual Restart Button

It is for deleting the alarm warning on the screen and to re-start the boiler. It aims to prevent the boiler's self, re-starting and forces the operator to go next to the boiler physically to see the alarm and take necessary actions.

Burner Alarm Reset

For some burner types, burner alarm reset button may be placed on the boiler control board instead of burner control board. This button is to reset the burner alarm from the boiler control board.



ATTENTION: Information in this section is to give general idea to the operator, about boiler control board and main controls on it. The number of equipment, switches and controllers may vary according to the purchased configuration. The main source for reference shall be the special "electrical control board diagram" that is provided to the customer during the system installation.



PLEASE KEEP THE FOLLOWING DOCUMENTS WHICH HAS BEEN SUPPLIED BY AKKAYA IN A SAFE LOCATION DURING THE ENTIRE LIFETIME OF THE BOILER

- a. USER MANUAL**
- b. P&ID (PIPING AND INSTRUMENTATION DIAGRAM)**
- c. ITEM LIST**
- d. TECHNICAL FILE, INCLUDING CERTIFICATES**
- e. ELECTRICAL WIRING DIAGRAM WITH CONTROL ALGORITHM**

A COPY OF THIS USER MANUAL WITH THE ABOVE DOCUMENTS HAS BEEN RECEIVED BY US AND THE EXPLANATION OF THIS USER MANUAL HAS BEEN DONE BY AKKAYA TECHNICAL SERVICE. WE AGREE TO OPERATE THE BOILER UNDER THE CONDITIONS EXPLAINED IN THIS USER MANUAL.

CUSTOMER NAME:

ADDRESS:

DATE:

SIGNED BY (NAME-SURNAME-SIGNATURE):



 1. OSB Yerli Su Sokak No: 2
Selçuklu /Konya / Turkey

 **+90 332 248 92 21**
+90 332 248 91 45

 **+90 332 248 77 10**

 **akkaya@akkaya.com.tr**

 **akkaya.com.tr**

   **/akkayaboilers**